



*Weksler® Pressure and
Temperature Instruments
Full Line Catalog*



TABLE OF CONTENTS

	PAGE		PAGE
Selecting A Pressure Gauge	4	BIMETAL THERMOMETERS	
TEST GAUGES		Introduction	45
±0.25% Accuracy (TA)	6	Adjustable Angle AF, CF	46
General Purpose Digital Gauges (WDG)	7	3" Dial Size – Rigid Forms 3A, 3S	47
ROYAL & REGAL GAUGES		5" Dial Size – Rigid Forms 5A, 5S	48
Process Gauges AA	11-13	3" Dial Size – Heavy Duty H3A, H3S	49
Receiver Gauges AR	14	Pocket Bimetal IR, 2R, 2T	50
Industrial Gauges BA	15-17	Standard Threaded Thermowells	51
Altitude Gauges BM, BN	18	GLASS THERMOMETERS	
Refrigeration & Ammonia Gauges BP, BQ	19	Adjustable Glass Thermometers	
100mm Gauges BA4CY	20	A735, A935	55
Duplex Gauges BB	21	Dimensions, Thermowells	56
Differential Gauges BC, BD	22		
Reid Vapor Test RV	23		
Bellows Gauges BL	24		
Metric and Dual Scales	25		
Case Style & Dimensions	26-28		
GAUGE ACCESSORIES			
Accessories/Options/Tools	31-33		
Snubbers	34		
Gauge Cocks, Needle Valves, Siphons	35		
ECONOMY UTILITY GAUGES			
Dry Gauges	39		
Liquid Filled Gauges	40-41		
Contractor Gauges	42		

RANGE

The maximum operating pressure should not exceed 75% of the full-scale range. The normal operating range should be in the middle half of the range (between 25% and 75% of the full-scale range); whenever possible.

DIAL SIZE

Select a dial size that allows you to comfortably read the dial from the normal distance when installed.

PRESSURE SYSTEM MATERIAL

The media to which the gauge will be subjected is critical to the selection of the proper material for the Bourdon tube, bellows, and socket.

Weksler models are offered with:

- Phosphor bronze Bourdon tube (or bellows) with brass sockets.
- 316 stainless steel Bourdon tube (or bellows) with 316 stainless steel sockets.
- 316 stainless steel Bourdon tube with alloy steel sockets.
- Monel Bourdon tubes with Monel sockets.

For applications where the above materials may not be suitable, a diaphragm seal will be necessary to protect the pressure gauge system.

ACCURACY

Select a gauge with the desired accuracy as follows:

- ±¼% – Test gauges only (not for in-line service)
- ±½% – Weksler Royal gauges (4½" dial size and larger) and Weksler digital gauges (2½" case size)
- ±1% – Weksler Regal gauges, 100 MM Gauge, EA14 gauge
- ±2-1-2% – Weksler duplex, differential and low pressure gauges
- ±3-2-3% – Weksler BY12, BY42, UA15, UA20, UA25, UA35 series utility gauges

MOVEMENT

Select either a gauge with 300 series stainless steel movement for long wear or a gauge with bronze or brass movement for applications where vibration and pulsation are not present.

CASE

A wide variety of case styles and materials are offered. Determine how the gauge is to be mounted: direct, surface (wall) or flush (in panel). Determine the desired case materials: polypropylene (or phenol); aluminum (black enameled) or stainless steel (300 series).

Determine case type:

- Safety (solid front with blow-out back)
- Standard (open front with rubber blow-out disc at rear)

Note – All safety case styles are designated by a number. Standard case styles are designated by a letter.

WINDOW

A glass face is standard in most gauges. If breakage is a concern, a plastic or shatterproof glass face is optional at extra cost on most Weksler Royal and Regal gauges. (Glycerin filled and sanitary gauges have plastic face as standard).

POINTER

All Weksler gauges (except utility types) have adjustable pointers. This permits pointer repositioning during calibration check or allows maximum precision at a specific point.

TEMPERATURE

The ambient temperature to which the gauge will be subjected should not exceed 150°F. If higher temperatures are encountered the gauge must be isolated from the source of heat. The temperature of the media to which the gauge is subjected to is also critical. Gauges with phosphor bronze Bourdon tubes should not be subjected to process temperatures in excess of 150°F. Gauges with metal cases and either 316 stainless steel or monel bourdons can withstand higher process temperatures, but as temperature exceeds 150°F hardening of the gasketing and discoloration of the dial may occur. In addition, accuracy will be affected by approximately 1.5% per 100°F. Both 316 stainless steel and monel gauges in metal cases will withstand 750°F for short periods of time without rupture, but other parts of the gauge will be destroyed and calibration will be lost.

VIBRATION

If present, a glycerin filled gauge is recommended.

PULSATION

If present, a pressure snubber or throttle screw is recommended.

WARNING: Misuse, Including Excessive Pressure, Vibration, Pulsation, Temperature And Corrosion May Cause Failure That Can Result in Damage Or Injury. We suggest that users of Pressure Gauges refer to American National Standard ASME B40.1 entitled "Gauges, Pressure And Vacuum Indicating Dial Type – Elastic Element" for guidance in Gauge selection. This document may be obtained from American Society of Mechanical Engineers (ASME) United Engineering Center, 345 East 47th Street, New York, N.Y. 10017.

TEST & DIGITAL GAUGES

Test Gauges	6
Digital Gauges	7

STANDARD FEATURES

Movement: Precision design, stainless steel rotary gear type. Wear-resistant, and virtually frictionless for long, accurate service.

Dial & Pointer: Mirrored dial and balanced knife-edge aluminum pointer permits reading without parallax error. Dial surface is white, with black numerals and graduations in a full 270° arc. Graduation lines are same width as the knife edge on pointer.

Dial Sizes: 4½", 6"

Connection Location: ¼ or ½ male NPT

Case: Choice of two black enameled die cast aluminum cases, solid front, safety type depending on connection.

Style 4: Back flanged type, bayonet ring, for surface or direct mounting. Bottom connected.

Style 6: Hinged front flush mount type, back connected.

Test Gauges are designed specifically for periodic bench testing and recalibration of production type gauges. They are also recommended for use in test cells such as on research projects, and as portable instruments for field inspectors and traveling engineers. Test gauges are not suggested for continuous duty in service installations.

STANDARD RANGES

RANGE CODE	DIAL RANGES	FIGURE INTERVALS	SMALLEST GRADUATION
PC	0/15 psi	1 psi	0.05 psi
PD	0/30 psi	2 psi	0.10 psi
PE	0/60 psi	5 psi	0.20 psi
PF	0/100 psi	5 psi	0.50 psi
PG	0/160 psi	10 psi	1.0 psi
PH	0/200 psi	10 psi	1.0 psi
PJ	0/300 psi	20 psi	1.0 psi
PK	0/400 psi	20 psi	2.0 psi

STANDARD RANGES

RANGE CODE	DIAL RANGES	FIGURE INTERVALS	SMALLEST GRADUATION
PM	600 psi	0/50 psi	2.0 psi
PO	800 psi	0/50 psi	5.0 psi
PP	1000 psi	0/50 psi	5.0 psi
PR	1500 psi	0/100 psi	5.0 psi
PS	2000 psi	0/100 psi	10.0 psi
PT	3000 psi	0/200 psi	10.0 psi
PV	5000 psi	0/500 psi	20 psi
PY	10,000 psi	0/1000 psi	50 psi

BOURDON TUBE AND SOCKET

CATALOG NO.	BOURDON TUBE & SOCKET MATERIAL	DIAL SIZE
TA14 ⁽²⁾	Phosphor Bronze	4½"
TA16 ⁽²⁾	Tube, Brass Socket	6"
TA24	K Monel Tube, and Socket	4½"
TA26		6"

NOTES:

- (1) The accuracy of measurement is influenced by the ambient temperature. The Weksler test gauge is calibrated to be accurate to within ¼ of 1% of full scale range at 77°F. (25°C). Using the gauge in ambient temperatures other than this requires the application of a correction of 0.02% of the indicated pressure for each 1°F. The correction is minus if the temperature is higher and plus if lower than 77°F.
- (2) 0/400 psi maximum range.
- (3) Refer to page 26 for case dimensions.

HOW TO ORDER

T A 1 4 4 P K 4 L W

1. Basic 4-digit Catalog No. From Table Above _____
2. Case Style "4½" (Bottom Connection) or "6" (Back Connection) _____
3. Range Code From Range Tables Above _____
4. Thread Size: 4 = ¼ NPT Male (Standard); 2 = ½ NPT Male _____
5. Connection Location: L = Lower (Bottom); or R = Rear (Back) _____
6. Dial Color: W = White (Standard), B = Black (Optional) _____

General Purpose Digital Gauge Type WDG4251L $\pm 1/2\%$ of Span Terminal Point Accuracy

STANDARD FEATURES

The Weksler WDG4251L offers 0.5% of span accuracy, while the stainless steel sensor and socket make this product suitable not only for dry air applications but for other media as well.

This product offers selectable units of measure so rather than purchasing one gauge for each unit of measure required, the solution is one gauge for multiple units of measure.

The WDG4251L is standard with many features not offered, or offered only as options, on competitor's digital gauge products, such as peak hold and 5 digit display. When compared to mechanical gauges the WDG4251L offers overall enhanced value.

- Enhanced value versus mechanical gauges
- No-nonsense accuracy – $\pm 0.5\%$ full scale accuracy
- Easy-to-read – 5 digit display with .48" character size, backlite display feature to enhance visibility
- Versatile – nine engineering units and stainless steel sensor suitable for a variety of applications
- Standard features – max.-pressure indication; ranges from vacuum to 20,000 psi, including compound
- Competitively priced
- IP65



PRODUCT SPECIFICATIONS

Type no.:	WDG4251L
Accuracy:	$\pm 0.5\%$ of span
Case Size:	2 1/2"
Case Material:	Polycarbonate
Wetted Parts:	17-4 PH stainless steel sensor; 316L stainless steel socket
Socket Size:	1/4 NPT
Connection:	Lower
Ranges:	Vac. thru 20,000 psi (see engineering units below for other units of measurement)
Battery:	Two AA alkaline batteries; 2000 hours battery life
Overpressure:	
Proof Pressure: % of Span	Vac – 2,000: 200% 3,000 – 5,000: 150% 7,500 – 20,000: 120%
Burst Pressure: % of Span	Vac – 2,000: 800% 3,000 – 5,000: 500% 7,500 – 20,000: 300%
Cycle Life:	10 million cycles
Vibration:	MIL-STD-202G, Method 201A
Shock:	MIL-STD-202G, Method 213B, Test Condi- tion K
Operating Temp.:	-4 °F to 140°F, (-20 °C to 60 °C) ambient temp.; -4 °F to 176 °F, (-20 °C to 80 °C) process media temp
Storage Temp.:	Batteries Installed: -4°F to 140°F, (-20°C to 60°C) Batteries Removed: -4°F to 176°F, (-20°C to 80°C)
Temp. Coef.:	0.04%/°F (-20 °F to 180 °F) zero and span Reference Temp. 70 °F
Update Rate:	1Hz, 2Hz, 4Hz
Agency Approvals:	CE/UKCA, UL & cUL
Packaging:	Individual carton

DISPLAY

Type:	LCD	
Display Digits:	5	
Display Resolution:	Full Scale Numerical Value	Display Resolution
	$\geq -15 > 0$	-XX.000
	$> 0 < 2$	X.0000
	$\geq 2 < 20$	XX.000
	$\geq 20 < 200$	XXX.00
	$\geq 200 < 2000$	XXXX.0
	$\geq 2000 < 19,999$	XXXXX
Character Height:	0.48"	
Backlight:	OFF by default	
Battery:	Four-level battery indication	

KEYBOARD FUNCTIONS

On/Off:	Manually turns unit on and off (four options: never, 5 min., 10 min., 20 min.)
Maximum (Peak Hold):	Displays max. value when activated
Zero/Clear:	Zeros display or clears max. value when activated
Engineering Units:	psi, in. Hg, cmHg, mmHg, kPa, MPa, bar, kg/cm ² , ftHz0
Field Calibration:	Zero and span

W-DG4251L GAUGE DIMENSIONS

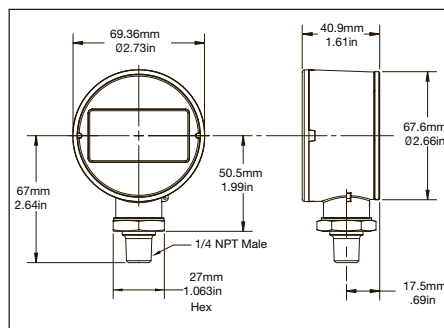

CATALOG NUMBERS

Dial Size	2 1/2"
Connection Location	Bottom
Connection NPT	1/4
Range	
30"/0/vac.	WDG4251LVC4L
0-15 psi	WDG4251LPC4L
0-30 psi	WDG4251LPD4L
0-60 psi	WDG4251LPE4L
0-100 psi	WDG4251LPF4L
0-150 psi	WDG4251LP14L
0-200 psi	WDG4251LPH4L
0-300 psi	WDG4251LPJ4L
0-500 psi	WDG4251LPL4L
0-1000 psi	WDG4251LPP4L
0-2000 psi	WDG4251LPS4L
0-3000 psi	WDG4251LPT4L
0-5000 psi	WDG4251LPV4L
0-10,000 psi	WDG4251LPY4L
0-15,000 psi	WDG4251LPZ4L
0-20,000 psi	WDG4251LP24L

**TO ORDER SPECIFY 12 DIGIT CATALOG
NUMBER FROM TABLE ABOVE**

ROYAL & REGAL GAUGES

Process Gauges	11-13
Receiver Gauges.....	14
Industrial Gauges.....	15-17
Altitude Gauges	18
Refrigeration & Ammonia Gauges.....	19
100mm Gauges	20
Duplex Gauges.....	21
Differential Gauges	22
Special Application Gauges	23
Bellows Gauges	24
Metric Scales.....	25
Case Styles & Dimensions	26-29

STANDARD FEATURES

Movement: All 300 series stainless steel

Pointer: Geared micrometer adjustable, balanced

Dial: White enameled aluminum with black graduations and numerals 270° Arc

Dial Sizes: 4½"

Thread Size: ¼ male NPT; ½ male NPT

Connection Location: Lower (Bottom), Back (Rear)

Case: Standard with style #2 case; Polypropylene safety case (solid front, blow-out back) suitable for surface or direct mounting.

Bourdon Tube: 316 stainless steel

Socket: 316 stainless steel



PRESSURE RANGES

CODE NO.	DIAL RANGES	FIGURE INTERVALS	SMALLEST GRADUATION
PC	0-15 psi	1 psi	.25 psi
PD	0-30 psi	5 psi	.5 psi
PE	0-60 psi	10 psi	1 psi
PF	0-100 psi	10 psi	1 psi
PG	0-160 psi	20 psi	2 psi
PH	0-200 psi	20 psi	2 psi
PJ	0-300 psi	50 psi	5 psi
PK	0-400 psi	50 psi	5 psi
PM	0-600 psi	50 psi	10 psi
PO	0-800 psi	100 psi	10 psi
PP	0-1000 psi	100 psi	10 psi
PR	0-1500 psi	200 psi	10 psi
PS	0-2000 psi	200 psi	20 psi
PT	0-3000 psi	500 psi	20 psi
PV	0-5000 psi	500 psi	50 psi
PY	0-10,000 psi	1000 psi	100 psi
PZ	0-15,000 psi	3000 psi	100 psi
P2	0-20,000 psi	2000 psi	200 psi

VACUUM RANGES

CODE NO.	DIAL RANGES	FIGURE INTERVALS	SMALLEST GRADUATION
VC	30"-0 Hg. Vac	3"	.2"

DESCRIPTION

CATALOG NO.	GAUGE TYPE
AA44	Standard "Dry" Gauge
AS44	Hermetically Sealed "Dry" Gauge
AY44	Glycerin Filled Gauge

CASE STYLE	
OPTIONAL CASE STYLE*	
LOWER CONNECT	BACK CONNECT
#4 Aluminum Safety	#4 Aluminum Safety
	#6 Aluminum Flush

*Extra cost.

COMPOUND RANGES

CODE NO.	DIAL RANGES	FIGURE INTERVALS	SMALLEST GRADUATION
CA	30"-0- 15 psi	5" & 3 psi	.5"/2 psi
CB	30"-0- 30 psi	10" & 5 psi	1"/5 psi
CC	30"-0- 60 psi	10" & 10 psi	1"/1 psi
CD	30"-0-100 psi	30" & 10 psi	2"/1 psi
CE	30"-0-150 psi	30" & 20 psi	5"/2 psi
CF	30"-0-200 psi	30" & 20 psi	5"/2 psi
CG	30"-0-300 psi	30" & 50 psi	10"/5 psi
CI	30"-0-600 psi	30" & 100 psi	10"/10 psi

NOTES:

- Royal Gauges are calibrated in accordance with ASME B40.1 Grade 2A (±1/2%).
- Metric dials can be furnished, see page 25.

HOW TO ORDER

A A 4 4 2 P F 4 L W ()

- Basic 4-digit Catalog No. From Table Above _____
- Polypropylene case style #2 standard or case style from above table _____
- Range Code From Range Tables Above _____
- Thread Size: 4 = ¼ Npt Male (Standard); 2 = ½ Npt Male _____
- Connection Location: L = Lower (Bottom), R = Back (Rear) _____
- Dial Color: W = White _____
- If Any Gauge Options Are Desired – Specify Option Code(s) From Page 35 _____

STANDARD FEATURES

Movement: All 300 series stainless steel
Pointer: Geared micrometer adjustable, balanced
Dial: White enameled aluminum with black graduations and numerals 270° Arc
Dial Sizes: 4½"
Thread Size: ¼ male NPT; ½ male NPT
Connection Location: Lower (Bottom), Back (Rear)
Case: Standard with style #2 case; Polypropylene safety case (solid front, blow-out back) suitable for surface or direct mounting (standard).

Bourdon Tube: Monel
Socket: Monel



PRESSURE RANGES

CODE NO.	DIAL RANGES	FIGURE INTERVALS	SMALLEST GRADUATION
PC	0-15 psi	1 psi	.25 psi
PD	0-30 psi	5 psi	.5 psi
PE	0-60 psi	10 psi	1 psi
PF	0-100 psi	10 psi	1 psi
PG	0-160 psi	20 psi	2 psi
PH	0-200 psi	20 psi	2 psi
PJ	0-300 psi	50 psi	5 psi
PK	0-400 psi	50 psi	5 psi
PM	0-600 psi	50 psi	10 psi
PO	0-800 psi	100 psi	10 psi
PP	0-1000 psi	100 psi	10 psi
PR	0-1500 psi	200 psi	10 psi
PS	0-2000 psi	200 psi	20 psi
PT	0-3000 psi	500 psi	20 psi
PV	0-5000 psi	500 psi	50 psi
PY	0-10,000 psi	1000 psi	100 psi

VACUUM RANGES

CODE NO.	DIAL RANGES	FIGURE INTERVALS	SMALLEST GRADUATION
VC	30"-0 Hg. Vac	3"	.2"

DESCRIPTION

CATALOG NO.	GAUGE TYPE
AA24	Standard "Dry" Gauge
AS24	Hermetically Sealed "Dry" Gauge
AY24	Glycerin Filled Gauge

CASE STYLE

OPTIONAL CASE STYLE*	
LOWER CONNECT	BACK CONNECT
#4 Aluminum Safety	#4 Aluminum Safety
#4 Aluminum Safety	#6 Aluminum Flush

*Extra cost.

COMPOUND RANGES

CODE NO.	DIAL RANGES	FIGURE INTERVALS	SMALLEST GRADUATION
CA	30"-0- 15 psi	5" & 3 psi	.5/2 psi
CB	30"-0- 30 psi	10" & 5 psi	1/5 psi
CC	30"-0- 60 psi	10" & 10 psi	1/1 psi
CD	30"-0-100 psi	30" & 10 psi	2/1 psi
CE	30"-0-150 psi	30" & 20 psi	5/2 psi
CF	30"-0-200 psi	30" & 20 psi	5/2 psi
CG	30"-0-300 psi	30" & 50 psi	5/2 psi
CI	30"-0-600 psi	30" & 100 psi	10/5 psi

NOTES:

- Royal Gauges are calibrated in accordance with ASME B40.1 Grade 2A (±1/2%).
- Metric dials can be furnished, see page 25.

HOW TO ORDER

A A 2 4 2 P F 4 L W ()

- Basic 4-digit Catalog No. From Table Above _____
- Polypropylene case style #2 standard or case style from above table _____
- Range Code From Range Tables Above _____
- Thread Size: 4 = ¼ Npt Male (Standard); 2 = ½ Npt Male _____
- Connection Location: L = Lower (Bottom), R = Back (Rear) _____
- Dial Color: W = White _____
- If Any Gauge Options Are Desired – Specify Option Code(s) From Page 35 _____

STANDARD FEATURES

Movement: All 300 series stainless steel
Pointer: Geared micrometer adjustable, balanced
Dial: White enameled aluminum with black graduations and numerals 270° Arc
Dial Sizes: 6", 8 1/2"
Thread Size: 1/4 male NPT; 1/2 male NPT
Connection Location: Lower (Bottom), Back (Rear)
Case: Standard with style #4 case; Aluminum safety case (solid front, blow-out back) suitable for surface or direct mounting.

Optional Case Style:
 (6" size only)
Back connect #6 Aluminum Flush
Bourdon Tube: See Table Below
Socket: See Table Below



PRESSURE RANGES

CODE NO.	DIAL RANGES	FIGURE INTERVALS	SMALLEST GRADUATION
PC	0-15 psi	1 psi	.25 psi
PD	0-30 psi	5 psi	.5 psi
PE	0-60 psi	10 psi	1 psi
PF	0-100 psi	10 psi	1 psi
PG	0-160 psi	20 psi	2 psi
PH	0-200 psi	20 psi	2 psi
PJ	0-300 psi	50 psi	5 psi
PK	0-400 psi	50 psi	5 psi
PM	0-600 psi	50 psi	10 psi
PO	0-800 psi	100 psi	10 psi
PP	0-1000 psi	100 psi	10 psi
PR	0-1500 psi	200 psi	10 psi
PS	0-2000 psi	200 psi	20 psi
PT	0-3000 psi	500 psi	20 psi
PV	0-5000 psi	500 psi	50 psi
PY	0-10,000 psi	1000 psi	100 psi
PZ	0-15,000 psi	3000 psi	100 psi
P2	0-20,000 psi	2000 psi	200 psi

COMPOUND RANGES

CODE NO.	DIAL RANGES	FIGURE INTERVALS	SMALLEST GRADUATION
CA	30"-0- 15 psi	5" & 3 psi	.5"/2 psi
CB	30"-0- 30 psi	10" & 5 psi	1"/5 psi
CC	30"-0- 60 psi	10" & 10 psi	1"/1 psi
CD	30"-0-100 psi	30" & 10 psi	2"/1 psi
CE	30"-0-150 psi	30" & 20 psi	5"/2 psi
CF	30"-0-200 psi	30" & 20 psi	5"/2 psi
CG	30"-0-300 psi	30" & 50 psi	10"/5 psi
CI	30"-0-600 psi	30" & 100 psi	10"/10 psi

VACUUM RANGES

CODE NO.	DIAL RANGES	FIGURE INTERVALS	SMALLEST GRADUATION
VC	30"-0 Hg. Vac	3"	.2"

BOURDON TUBE AND SOCKET

CATALOG NO.	BOURDON TUBE & SOCKET MATERIAL	DIAL SIZE	GAUGE TYPE
AA16	Brass/ Bronze	6"	Dry
AS16		6"	Herm. Seal.
AY16		6"	Liq. Fill
AA26	Monel	6"	Dry
AS26		6"	Herm. Seal.
AY26		6"	Liq. Fill
AA46	316 SS	6"	Dry
AS46		6"	Herm. Seal.
AY46		6"	Liq. Fill
AA48		8 1/2"	Dry (only)

CASE STYLES

OPTIONAL CASE STYLES*
BACK CONNECT
#6 Aluminum Flush (6" Back Conn. Only)

*Extra cost.

NOTES:

- Royal Gauges are calibrated in accordance with ASME B40.1 Grade 2A (±1/2%).
- Metric dials can be furnished, see page 25.

HOW TO ORDER

A A 4 6 4 P F 4 L W ()

- Basic 4-digit Catalog No. From Table Above _____
- Aluminum case style #4 standard or case style from above table _____
- Range Code From Range Tables Above _____
- Thread Size: 4 = 1/4 Npt Male (Standard); 2 = 1/2 Npt Male _____
- Connection Location: L = Lower (Bottom), R = Back (Rear) _____
- Dial Color: W = White _____
- If Any Gauge Options Are Desired – Specify Option Code(s) From Page 35 _____

STANDARD FEATURES

Movement: All 300 series stainless steel

Pointer: Geared micrometer adjustable, balanced

Dial: White enameled aluminum with black graduations and numerals 270° Arc

Dial Sizes: 4½"

Thread Size: ¼ male NPT; ½ male NPT

Connection Location: Lower (Bottom), Back (Rear)

Case: Standard with style #2 case; Polypropylene safety case (solid front, blow-out back) suitable for surface or direct mounting (standard).

Bourdon Tube: 316 stainless steel

Socket: 316 stainless steel

Receiver gauges are used with a transmitter (transducer) to translate distant point air signals into units of pressure, temperature, liquid level or flow. Outer scale marked with equal increments of transmitted signal, inner scale graduated with units of specific measured variable (i.e.: square root, %).



AR44

STANDARD RANGES (3-15 PSI SIGNAL)

CODE NO.	DIAL RANGES	FIGURE INTERVALS	SMALLEST GRADUATION
OC	0-100	1 psi	.25 psi
OH	0-10 Sq. Rt.	5 psi	.5 psi

BOURDON TUBE AND SOCKET

CATALOG NO.	BOURDON TUBE & SOCKET MATERIAL	DIAL SIZE	GAUGE TYPE
AR44	316 SS	4½"	Receiver

CASE STYLES

OPTIONAL CASE STYLE*	
LOWER CONNECT	BACK CONNECT
#4 Style Alum. Safety	#6 Style Alum. Flush

*Extra cost.

NOTES:

- Royal Gauges are calibrated in accordance with ASME B40.1 Grade 2A (±1/2%).

HOW TO ORDER

A R 4 4 2 O C 4 L W ()

- Basic 4-digit Catalog No. From Table Above _____
- Polypropylene Case Style #2 (Standard) or case style from above table _____
- Range Code From Range Tables Above _____
- Thread Size: 4 = ¼ Npt Male (Standard); 2 = ½ Npt Male _____
- Connection Location: L = Lower (Bottom), R = Back (Rear) _____
- Dial Color: W = White _____
- If Any Gauge Options Are Desired – Specify Option Code(s) From Page 35 _____

STANDARD FEATURES

Available in 3½" dial sizes, Regal pressure gauges are liquid fillable and field convertible for panel mounting. Both zero and span adjustments are standard. The gauge is available dry, liquid-filled, weatherproof or hermetically sealed.

- Designed for safety and long life
- All stainless, all-welded construction for long life
- ASME Grade 1A, ±1% accuracy of span.
- No stop pin to mask false zero reading – ensures safety and process control
- Bourdon tube, see table below
- Socket, see table below



BA43

PRESSURE RANGES

CODE NO.	DIAL RANGES	FIGURE INTERVALS	SMALLEST GRADUATION
PC	0-15 psi	1 psi	.25 psi
PD	0-30 psi	5 psi	.5 psi
PE	0-60 psi	10 psi	1 psi
PF	0-100 psi	10 psi	1 psi
PG	0-160 psi	20 psi	2 psi
PH	0-200 psi	20 psi	2 psi
PJ	0-300 psi	50 psi	5 psi
PK	0-400 psi	50 psi	5 psi
PM	0-600 psi	100 psi	10 psi
PO	0-800 psi	100 psi	10 psi
PP	0-1000 psi	100 psi	10 psi
PR	0-1500 psi	200 psi	10 psi
PS	0-2000 psi	200 psi	20 psi
PT	0-3000 psi	500 psi	20 psi
PV	0-5000 psi	500 psi	50 psi
PY	0-10,000 psi	1000 psi	100 psi
PZ	0-15,000 psi	3000 psi	100 psi

VACUUM RANGES

CODE NO.	DIAL RANGES	FIGURE INTERVALS	SMALLEST GRADUATION
VC	30"-0 Hg. Vac	3"	.2"

BOURDON TUBE AND SOCKET

CATALOG NO.	BOURDON TUBE & SOCKET MATERIAL	DIAL SIZE	GAUGE TYPE
BA13	Brass/Bronze ⁽¹⁾	3½"	Dry
BS13			Herm. Sealed
BY13			Liquid Fill
BA43	316 SS		Dry
BS43			Herm. Sealed
BY43			Liquid Fill

CASE STYLES

OPTIONAL CASE STYLE†*	
LOWER CONNECT	BACK CONNECT
"X" Style SS Back Flanged	"X" Style SS
	Back Flanged
	"U" Style SS
	U-Clamp
	"V" Style SS
	Front Flanged

†See page 26 for case dimensions. *Extra cost.

COMPOUND RANGES

CODE NO.	DIAL RANGES	FIGURE INTERVALS	SMALLEST GRADUATION
CA	30"-0- 15 psi	5" & 3 psi	.5"/.2 psi
CB	30"-0- 30 psi	10" & 5 psi	1"/.5 psi
CC	30"-0- 60 psi	10" & 10 psi	1"/.1 psi
CD	30"-0-100 psi	30" & 10 psi	2"/.1 psi
CE	30"-0-150 psi	30" & 20 psi	5"/.2 psi
CF	30"-0-200 psi	30" & 20 psi	5"/.2 psi
CG	30"-0-300 psi	30" & 50 psi	10"/.5 psi
CI	30"-0-600 psi	30" & 100 psi	10"/10 psi

NOTES:

1. Brass/Bronze maximum range is 1000 psi.
2. Metric dials available, see page 25.

HOW TO ORDER

B A 4 3 Y P F 4 L W ()

1. Basic 4-digit Catalog No. From Table Above _____
2. Stainless Steel Case Style "Y" Standard or case style from above table _____
3. Range Code From Range Tables Above _____
4. Thread Size: 4 = 1/4 Npt Male (only) _____
5. Connection Location: L = Lower (Bottom), R = Back (Rear) _____
6. Dial Color: W = White _____
7. If Any Gauge Options Are Desired – Specify Option Code(s) From Page 35 _____

Regal Industrial Gauge
±1.0% of Span Accuracy
Bronze/Brass
4 1/2" Dial Size

STANDARD FEATURES

Movement: All 300 series stainless steel
Pointer: Geared micrometer adjustable, balanced
Dial: White enameled aluminum with black graduations and numerals 270° Arc
Dial Sizes: 4 1/2"
Thread Size: 1/4 male NPT; 1/2 male NPT
Connection Location: Lower (Bottom), Back (Rear)
Case: Polypropylene safety case #2 (solid front, blow-out back) suitable for surface or direct mounting (standard).

Bourdon Tube: Bronze
Socket: Brass



BA14

PRESSURE RANGES

CODE NO.	DIAL RANGES	FIGURE INTERVALS	SMALLEST GRADUATION
PC	0-15 psi	1 psi	.25 psi
PD	0-30 psi	5 psi	.5 psi
PE	0-60 psi	10 psi	1 psi
PF	0-100 psi	10 psi	1 psi
PG	0-160 psi	20 psi	2 psi
PH	0-200 psi	20 psi	2 psi
PJ	0-300 psi	50 psi	5 psi
PK	0-400 psi	50 psi	5 psi
PM	0-600 psi	50 psi	10 psi
PO	0-800 psi	100 psi	10 psi
PP	0-1000 psi	100 psi	10 psi

VACUUM RANGES

CODE NO.	DIAL RANGES	FIGURE INTERVALS	SMALLEST GRADUATION
VC	30"-0 Hg. Vac	3"	.2"

BOURDON TUBE AND SOCKET

CATALOG NO.	BOURDON TUBE & SOCKET MATERIAL	DIAL SIZE	GAUGE TYPE
BA14	Brass/Bronze ⁽²⁾	4 1/2"	Dry
BS14			Herm. Seal.
BY14			Liquid Fill

CASE STYLES

OPTIONAL CASE STYLE*	
LOWER CONNECT	BACK CONNECT
#4 Style Alum. Safety	#4 Style Alum. Safety
	#6 Style Alum. Safety

*Extra cost.

COMPOUND RANGES

CODE NO.	DIAL RANGES	FIGURE INTERVALS	SMALLEST GRADUATION
CA	30"-0- 15 psi	5" & 3 psi	.5"/.2 psi
CB	30"-0- 30 psi	10" & 5 psi	1"/.5 psi
CC	30"-0- 60 psi	10" & 10 psi	1"/1 psi
CD	30"-0-100 psi	30" & 10 psi	2"/1 psi
CE	30"-0-150 psi	30" & 20 psi	5"/2 psi
CF	30"-0-200 psi	30" & 20 psi	5"/2 psi
CG	30"-0-300 psi	30" & 50 psi	10"/5 psi
CI	30"-0-600 psi	30" & 100 psi	10"/10 psi

NOTES:

- Regal gauges are calibrated in accordance with ASME B40.1 Grade 1A (±1%).
- Brass/Bronze maximum range is 1000 psi.

HOW TO ORDER

B A 1 4 2 P F 4 L W ()

- Basic 4-digit Catalog No. from Table Above _____
- Polypropylene Case Style #2 (Standard) or choose from above table _____
- Range Code From Range Tables Above _____
- Thread Size: 4 = 1/4 Npt Male (Standard); 2 = 1/2 Npt Male _____
- Connection Location: L = Lower (Bottom), R = Back (Rear) _____
- Dial Color: W = White _____
- If Any Gauge Options Are Desired – Specify Option Code(s) From Page 35 _____

STANDARD FEATURES

Movement: All 300 series stainless steel
Pointer: Geared micrometer adjustable, balanced
Dial: White enameled aluminum with black graduations and numerals 270° Arc
Dial Sizes: 6", 8 1/2", 12"
Thread Size: 1/4 male NPT; 1/2 male NPT
Connection Location: Lower (Bottom), Back (Rear)⁽³⁾
Case: 6", 8 1/2" Aluminum safety case (solid front, blow-out back) suitable for surface or direct mounting (4 Style).

12" Aluminum (open front)
 Back Flanged: (E style)
Bourdon Tube: See table below
Socket: See table below



PRESSURE RANGES

CODE NO.	DIAL RANGES	FIGURE INTERVALS	SMALLEST GRADUATION
PC	0-15 psi	1 psi	.25 psi
PD	0-30 psi	5 psi	.5 psi
PE	0-60 psi	10 psi	1 psi
PF	0-100 psi	10 psi	1 psi
PG	0-160 psi	20 psi	2 psi
PH	0-200 psi	20 psi	2 psi
PJ	0-300 psi	50 psi	5 psi
PK	0-400 psi	50 psi	5 psi
PM	0-600 psi	50 psi	10 psi
PO	0-800 psi	100 psi	10 psi
PP	0-1000 psi	100 psi	10 psi
PR	0-1500 psi	200 psi	10 psi
PS	0-2000 psi	200 psi	20 psi
PT	0-3000 psi	500 psi	20 psi
PV	0-5000 psi	500 psi	50 psi
PY	0-10,000 psi	1000 psi	100 psi
PZ	0-15,000 psi	3000 psi	100 psi
P2	0-20,000 psi	2000 psi	200 psi

VACUUM RANGES

CODE NO.	DIAL RANGES	FIGURE INTERVALS	SMALLEST GRADUATION
VC	30"-0 Hg. Vac	3"	.2"

BOURDON TUBE AND SOCKET

CATALOG NO.	BOURDON TUBE & SOCKET MATERIAL	DIAL SIZE	GAUGE TYPE
BA16	Brass/Bronze ⁽⁴⁾	6"	Dry
BS16			Herm. Seal.
BY16			Liq. Fill
BA18	Brass/Bronze ⁽⁴⁾	8 1/2"	Dry
BA49	316 SS	12"	Dry

CASE STYLES

OPTIONAL CASE STYLE*	
LOWER CONNECT	BACK CONNECT
#4 Style Alum. Safety (only)	#6 Style Alum. Flush
#4 Style Alum. Safety (only)	#4 Style Alum. Safety (only)
"E" Style Alum. Safety Back Flanged	Not Available in Back Connect

*Extra cost.

COMPOUND RANGES

CODE NO.	DIAL RANGES	FIGURE INTERVALS	SMALLEST GRADUATION
CA	30"-0- 15 psi	5" & 3 psi	.5"/2 psi
CB	30"-0- 30 psi	10" & 5 psi	1"/.5 psi
CC	30"-0- 60 psi	10" & 10 psi	1"/1 psi
CD	30"-0-100 psi	30" & 10 psi	2"/1 psi
CE	30"-0-150 psi	30" & 20 psi	5"/2 psi
CF	30"-0-200 psi	30" & 20 psi	5"/2 psi
CG	30"-0-300 psi	30" & 50 psi	10"/5 psi
CI	30"-0-600 psi	30" & 100 psi	10"/10 psi

NOTES:

1. Regal Gauges are calibrated in accordance with ASME B40.1 Grade 1A (±1%).
2. Metric dials can be furnished, see page 25.
3. 12" available in lower connect only
4. Brass/Bronze maximum range is 1000 psi.

HOW TO ORDER

B A 1 6 4 P F 4 L W ()

1. Basic 4-digit Catalog No. From Table Above _____
2. Case Style from Table Above _____
3. Range Code From Range Tables Above _____
4. Thread Size: 4 = 1/4 Npt Male (Standard); 2 = 1/2 Npt Male _____
5. Connection Location: L = Lower (Bottom), R = Back (Rear) _____
6. Dial Color: W = White _____
7. If Any Gauge Options Are Desired – Specify Option Code(s) From Page 35 _____

**Regal Altitude Gauges
±1.0% of Span Accuracy
316 SS Tube & Socket
3 1/2" & 4 1/2" Dial Size**

STANDARD FEATURES

Movement: All 300 series stainless steel
Pointer: Geared micrometer adjustable, balanced

Dial: White enameled aluminum with black graduations and numerals 270° Arc

Dial Sizes: 3 1/2" (2), 4 1/2"

Thread Size: 1/4 male NPT; 1/2 male NPT

Connection Location: Lower (Bottom), Back (Rear)

Case: Standard with style #2 case; 4 1/2" polypropylene safety case (solid front, blow-out back) suitable for surface or direct mounting (standard). 3 1/2" stainless steel case ("Y" style)

Bourdon Tube: 316 St. St.

Socket: 316 St. St.



BM1 ALTITUDE RANGES

RANGE CODE	TOTAL GRADUATION	FIGURE INTERVALS	SMALLEST GRADUATION
HA	0-30 ft.	5 ft.	1/2 ft.
HB	0-70ft.	10 ft.	1 ft.
HC	0-100 ft.	10 ft.	1 ft.
HD	0-160 ft.	20 ft.	2 ft.
HE	0-200 ft.	20 ft.	2 ft.
HF	0-250 ft.	25 ft.	5 ft.
HG	0-300 ft.	50 ft.	5 ft.
HH	0-400 ft.	50 ft.	5 ft.
HI	0-500 ft.	50 ft.	5 ft.
HJ	0-600 ft.	100 ft.	10 ft.

BN1 ALTITUDE/PRESSURE

RANGE CODE	TOTAL GRADUATION	FIGURE INTERVALS	SMALLEST GRADUATION
HO	15 psi & 35 ft.	3 psi & 5 ft.	1/4 psi & 1/2 ft.
HP	30 psi & 70 ft.	5 psi & 10 ft.	1/2 psi & 1 ft.
HQ	50 psi & 116 ft.	10 psi & 10 ft.	1 psi & 2 ft.
HW	60 psi & 140 ft.	10 psi & 20 ft.	1 psi & 2 ft.
HR	100 psi & 231 ft.	10 psi & 25 ft.	1 psi & 5 ft.
HS	150 psi & 345 ft.	20 psi & 20 ft.	2 psi & 5 ft.
HT	200 psi & 460 ft.	20 psi & 50 ft.	2 psi & 5 ft.
HU	300 psi & 690 ft.	50 psi & 50 ft.	5 psi & 10 ft.

BOURDON TUBE AND SOCKET

CATALOG NO.	BOURDON TUBE & SOCKET MATERIAL	DIAL SIZE	GAUGE TYPE
BM43	316 SS	3 1/2"	Altitude (only)
BN43			Altitude & PSI equivalent
BM44	316 SS	4 1/2"	Altitude (only)
BN44			Altitude & PSI equivalent

CASE STYLES

OPTIONAL CASE STYLE*	
LOWER CONNECT	BACK CONNECT
"X" Style SS Back Flng.	"U" Style SS U-Clamp
	"V" Style SS Front Flng "X" Style SS Back Flng
#4 Style Alum. Safety	#6 Style Alum. Flush

*Extra cost.

NOTES:

- Regal Gauges are calibrated in accordance with ASME B40.1 Grade 1A (±1%).
- 3 1/2" available in 1/4 male NPT only.

HOW TO ORDER

B M 4 4 2 H A 4 L W ()

- Basic 4-digit Catalog No. From Table Above _____
- Polypropylene case style #2 (Standard) or choose from above table _____
- Range Code From Range Tables Above _____
- Thread Size: 4 = 1/4 Npt Male (Standard); 2 = 1/2 Npt Male _____
- Connection Location: L = Lower (Bottom), R = Back (Rear) _____
- Dial Color: W = White _____
- If Any Gauge Options Are Desired – Specify Option Code(s) From Page 35 _____

Regal Refrigerant and Ammonia Gauges
±1.0% of Span Accuracy
3 1/2", 4 1/2" & 6" Dial Size

STANDARD FEATURES

Movement: All 300 series stainless steel
Pointer: Geared micrometer adjustable, balanced

Dial: White enameled aluminum with black graduations and numerals 270° Arc

Dial Sizes: 3 1/2", 4 1/2", 6"

Thread Size: 1/4 male NPT; 1/2 male NPT

Connection Location: Lower (Bottom), Back (Rear)

Case: 3 1/2", "Y" Style SS
 4 1/2", #2 Polypropylene safety
 6", #4 Aluminum safety

Bourdon Tube: 316 stainless steel

Socket: 316 stainless steel

Refrigerant gauges indicate both pressure and vacuum with corresponding temperature of refrigerants.

Ammonia gauges indicate both pressure and vacuum with corresponding temperature in ammonia systems.



BOURDON TUBE AND SOCKET				CASE STYLES	
CATALOG NO.	BOURDON TUBE & SOCKET MATERIAL	DIAL SIZE	GAUGE TYPE	OPTIONAL CASE STYLE*	
				LOWER CONNECT	BACK CONNECT
BP43	316 SS	3 1/2"	Ammonia	"X" Style SS Back Flng.	"U" Style SS U-Clamp
BQ43			Refrigeration		"V" Style SS Front Flng "X" Style SS Back Flng
BP44	316 SS	4 1/2"	Ammonia	#4 Style Alum. Safety	#6 Style Alum. Flush
BQ44			Refrigeration		
BP46	316 SS	6"	Ammonia	#4 Style Alum. Safety	#6 Style Alum. Flush
BQ46			Refrigeration		

*Extra cost.

BP AMMONIA GAUGE RANGES

DIAL RANGES	FIGURE INTERVALS	SMALLEST GRADUATION	RANGE CODE
30"-0-150 psi	30" & 25 psi	5" & 5 psi	AA
30"-0-300 psi	30" & 25 psi	5" & 5 psi	AB

BQ REFRIGERANT GAUGE RANGES			R12	R22	R134A	R502
30"-0-150 psi	30" & 25 psi	5" & 5 psi	FH	FN	F7	F5
30"-0-300 psi	30" & 25 psi	5" & 5 psi	FI	FO	F8	F6
300 psi	25 psi	5 psi	FF	FM	-	F4

NOTES:

- Any standard pressure or compound range, from 30 to 400# can be furnished for ammonia or refrigerant use, without temperature equivalent, at no additional charge
- Figure intervals and smallest graduations above are for 4 1/2" and 6" gauges. Graduations and intervals may vary for 3 1/2" dial sizes.

HOW TO ORDER

B P 4 4 2 A B 4 L W ()

- Basic 4-digit Catalog No. From Table Above _____
- Polypropylene case style #2 (Standard) or choose from above table _____
- Range Code From Range Tables Above _____
- Thread Size: 4 = 1/4 Npt Male (Standard); 2 = 1/2 Npt Male _____
- Connection Location: L = Lower (Bottom), R = Back (Rear) _____
- Dial Color: W = White, B = Black (optional) _____
- If Any Gauge Options Are Desired – Specify Option Code(s) From Page 35 _____

100mm Gauge
±1.0 % of Span Accuracy
316 SS Tube & Socket

STANDARD FEATURES

Movement: 300 series stainless steel

Pointer: Micrometer adjustable

Dial: White enameled aluminum

Dial Size: 100mm – dry or glycerin filled

Connection Location: 1/4 NPT or 1/2 NPT lower (bottom)

Case: Polished 304 stainless steel

Hermetically sealed

Dry version is liquid fillable in field

304 stainless steel case and bezel

Bourdon Tube & Socket: 316 stainless steel

- Suitable for a broad range of industrial applications



PRESSURE RANGES

SPECIFY 10 DIGIT CATALOG NUMBER FROM THE TABLE BELOW

RANGE DUAL SCALE PSI & KPA	10 DIGIT CATALOG NUMBERS			
	DRY GAUGE		GLYCERIN FILLED GAUGE	
	1/4 NPT	1/2 NPT	1/4 NPT	1/2 NPT
HG vac & 100-0 kPa	N/A	BA4CYVC2LW	N/A	BY4CYVC2LW
30"-0-30 psi & 100-0-200 kPa	BA4CYCB4LW	BA4CYCB2LW	BY4CYCB4LW	BY4CYCB2LW
30"-0-60 psi & 100-0-400 kPa	BA4CYCC4LW	N/A	BY4CYCC4LW	N/A
0-15 psi & 0-100 kPa	BA4CYPC4LW	BA4CYPC2LW	BY4CYPC4LW	BY4CYPC2LW
0-30 psi & 0-200 kPa	BA4CYPD4LW	BA4CYPD2LW	BY4CYPD4LW	BY4CYPD2LW
0-60 psi & 0-400 kPa	BA4CYPE4LW	BA4CYPE2LW	BY4CYPE4LW	BY4CYPE2LW
0-100 psi & 0-700 kPa	BA4CYPF4LW	BA4CYPF2LW	BY4CYPF4LW	BY4CYPF2LW
0-160 psi & 0-1100 kPa	BA4CYPG4LW	BA4CYPG2LW	BY4CYPG4LW	BY4CYPG2LW
0-200 psi & 0-1400 kPa	BA4CYPH4LW	BA4CYPH2LW	BY4CYPH4LW	BY4CYPH2LW
0-300 psi & 0-2100 kPa	BA4CYPJ4LW	BA4CYPJ2LW	BY4CYPJ4LW	BY4CYPJ2LW
0-600 psi & 0-4200 kPa	BA4CYPM4LW	BA4CYPM2LW	BY4CYPM4LW	BY4CYPM2LW
0-1000 psi & 0-7000 kPa	BA4CYP4LW	BA4CYP2LW	BY4CYP4LW	BY4CYP2LW
0-3000 psi & 0-21000 kPa	N/A	BA4CYPT2LW	N/A	BY4CYPT2LW

HOW TO ORDER

1. Select 10-digit Catalog No. From Table Above

STANDARD FEATURES

Movement: Bronze

Pointer: Non-adjustable red and black pointers

Dial: White enameled aluminum with black graduations and numerals.

Dial Sizes: 4½"

Thread Size: ¼ male NPT (only)

Connection Location: Lower or Rear (back)

Case: Suitable for direct or surface mounting.

Lower – (bottom) connect available in "A" style aluminum flanged case (only).

Back – (rear) connect "A" style (standard) "W" style (optional) aluminium flush

The Weksler Type BB14A duplex gauge is used to display two separate input pressures on the same gauge for comparison purposes.



BB14A

NOTES:

1. Regal Duplex Gauges are calibrated in accordance with ASME B40.1 Grade A (±1% middle third). See page 4 of this catalog for further reference to ASME B40.1.
2. Metric dials can be furnished. See Page 25.

CATALOG NO.& SOCKET	BOURDON TUBE MATERIAL	MAXIMUM PRESSURE (psi)	DIAL SIZE (INCHES)	STANDARD CASE
BB14	Phosphor Bronze Bourdon Forged Brass Socket	1000	4½	Style "A" ⁽¹⁾ Style "W" ⁽²⁾

NOTE: BB1 series not available with safety cases.

1. Aluminum back flanged, bottom connection only.
2. Aluminum hinged, back connection only.

PRESSURE RANGES

CODE NO.	DIAL RANGES	FIGURE INTERVALS	SMALLEST GRADUATION
PD	0-30 psi	5 psi	.5 psi
PE	0-60 psi	10 psi	1 psi
PF	0-100 psi	10 psi	1 psi
PG	0-160 psi	20 psi	2 psi
PH	0-200 psi	20 psi	2 psi
PJ	0-300 psi	50 psi	5 psi
PK	0-400 psi	50 psi	5 psi
PM	0-600 psi	50 psi	10 psi
PO	0-800 psi	100 psi	10 psi
PP	0-1000 psi	100 psi	10 psi

COMPOUND RANGES

CODE NO.	DIAL RANGES	FIGURE INTERVALS	SMALLEST GRADUATION
CA	30"-0- 15 psi	10" & 2 & 15 psi	1" / 5 psi
CB	30"-0- 30 psi	10" & 5 psi	1" / 1 psi
CC	30"-0- 60 psi	10" & 10 psi	1" / 1 psi
CD	30"-0-100 psi	30" & 10 psi	2" / 1 psi
CE	30"-0-150 psi	30" & 25 psi	5" / 5 psi
CF	30"-0-200 psi	30" & 20 psi	5" / 5 psi
CG	30"-0-300 psi	30" & 50 psi	10" / 5 psi

HOW TO ORDER

B B 1 4 A C C 4 L W ()

1. Basic 4-digit Catalog No. From Table Above _____
2. Case Style Code A for lower conn., W for back conn. _____
3. Range Code From Range Tables Above (See notation above) _____
4. Thread Size: 4 = ¼ Npt Male (only) _____
5. Connection Location: L = Lower (Bottom); or R = Rear (Back) _____
6. Dial Color: W = White (Standard), B = Black (Optional) _____
7. If Any Gauge Options Are Desired – Specify Option Code(s) From Page 35 _____

**Regal Differential Gauges
±2-1-2% of Span Accuracy
4½" & 6" Dial Size**

STANDARD FEATURES

Movement: Bronze

Pointer: Geared micrometer adjustable

Dial: White enameled aluminum. Black graduations and numerals

Dial Sizes: 4½", 6"

Thread Size: ¼ male NPT only

Connection Location: 4½" lower (bottom)
6" lower (bottom)

Case: Suitable for direct or surface mounting.
Available in "A" style aluminum case only.

To measure the difference between two pressure sources, apply high pressure, then low pressure. Read differential pressure on the gauge. BC designed with "0" at top center, BD with "0" at the left.



BC GAUGES RANGE TABLE

CODE NO.	DIAL RANGES	FIGURE INTERVALS	SMALLEST GRADUATION	STATIC PRESSURE LIMITS
DA	10-0- 10 psi	2 psi	0.5 psi	30 psi
DB	15-0- 15 psi	3 psi	0.2 psi	60 psi
DC	30-0- 30 psi	5 psi	1 psi	120 psi
DD	50-0- 50 psi	10 psi	1 psi	200 psi
DE	100-0-100 psi	20 psi	2 psi	300 psi
DF	200-0-200 psi	50 psi	5 psi	600 psi
DG	300-0-300 psi	100 psi	10 psi	900 psi
DH	400-0-400 psi	100 psi	10 psi	1200 psi

BD GAUGES RANGE TABLE

CODE NO.	DIAL RANGES	FIGURE INTERVALS	SMALLEST GRADUATION	STATIC PRESSURE LIMITS
PB	*0-10 psi	2 psi	¼ psi	45 psi
P5	**0-20 psi	2 psi	⅓ psi	30 psi
PD	0-30 psi	5 psi	½ psi	60 psi
PE	0-60 psi	10 psi	1 psi	120 psi
PF	0-100 psi	10 psi	1 psi	200 psi
PG	0-160 psi	20 psi	2 psi	300 psi
PH	0-200 psi	20 psi	2 psi	300 psi
PJ	0-300 psi	50 psi	5 psi	450 psi
PK	0-400 psi	50 psi	5 psi	600 psi
PM	0-600 psi	50 psi	10 psi	900 psi
PO	0-800 psi	100 psi	10 psi	1200 psi
PP	0-1,000 psi	100 psi	10 psi	1500 psi

*Only available with BD44, **180° dial arc

CATALOG NO.	BOURDON TUBE & SOCKET MATERIAL	DIAL SIZE (Inches)	STD. CASE
BC14 or BD14	Phosphor Bronze	4½	Style "A"
BC16 or BD16	Forged Brass Socket	6	Style "A"
BC44 or BD44	Stainless Steel, 316	4½	Style "A"

NOTES:

1. Regal Differential Gauges are calibrated in accordance with ASME B40.1 Grade A (±1% middle third). See page 4 of this catalog for further reference to ASME B40.1.

HOW TO ORDER

B C 1 6 A D D 4 L W ()

1. Basic 4-digit Catalog No. From Table Above _____
2. Case Style Code "A" (only) _____
3. Range Code From Range Tables Above (See notation above) _____
4. Thread Size: 4 = ¼ Npt Male (only) _____
5. Connection Location: L = Lower (Bottom) _____
6. Dial Color: W = White (Standard), B = Black (Optional) _____
7. If Any Gauge Options Are Desired – Specify Option Code(s) From Page 35 _____

Special Application Gauge
RV14, ASME B 40.1
Grade 2A ($\pm 0.5\%$ of span)
4½" Dial Size

STANDARD FEATURES

RV14 Reid Vapor Test Gauge

The Weksler RV14 is a specialized pressure gauge used by the petroleum industry to measure vapor pressures of various petroleum products.

- Accuracy ASME B 40.1 Grade 2A ($\pm 0.5\%$ of span)
- Dial Size 4½" only
- White dial and black pointer



RV14

SPECIFICATIONS

GAUGE TYPE NUMBER	DIAL SIZE (INCHES)	CASE & RING MATERIAL FINISH	BOURDON TUBE & TIP MATERIAL (ALL JOINTS WELDED)	SOCKET MATERIAL	PRESSURE RANGE (PSI)	POINTER	MOVEMENT	NPT CONN.
Reid Vapor Test RV14	4½	Case: Aluminum black epoxy coated	Phosphor Bronze Tip: Brass (All joints silver brazed)	Brass	15/600	Micrometer Adjustable	Stainless steel Teflon coated, pinion and sector shaft, rotary geared	¼

STANDARD RANGES

CODE	RANGE PSI	FIGURE INTERVAL	MINOR GRADUATION
PC	0/15	1	0.1
PD	0/30	2	0.2
PE	0/60	4	0.25
PF	0/100	5	0.5
PH	0/200	10	1
PI	0/250	10	1
PJ	0/300	10	1
PK	0/400	20	2
PM	0/600	20	2

HOW TO ORDER

R V 1 4 4 P C 4 L W

1. Basic 4-digit Catalog No. RV14 _____
2. Case Style Code "4" (only case available) _____
3. Range Code From Range Tables Above _____
4. Thread Size: 4 = ¼ Npt Male (only thread size available) _____
5. Connection Location: L = Lower (Bottom) _____
6. Dial Color: W = White _____

**Low Pressure Gauges –
Bellows Type
±2-1-2% of Span Accuracy
4½" Dial Size**

STANDARD FEATURES

Movement: Bronze
Pointer: Balanced Slotted adjustable
Dial: White enameled aluminum. Black graduations and numerals
Thread Size: ¼ male NPT; ½ male NPT
Connection Location: Lower or Rear (back)
Case: Style "2" polypropylene safety suitable for direct or surface mounting.

Ideal for applications under 15 psi.



BL44

NOTES:

1. Regal Low Pressure Gauges are calibrated in accordance with ASME B40.1 Grade A (±1% middle third). See page 4 of this catalog for further reference to ASME B40.1.

RANGES FOR BELLOWS GAUGES

CODE NO.	DIAL RANGES	FIGURE INTERVALS	SMALLEST GRADUATION	DIAL ARC	
				BL1	BL4
PA	0 to 5 psi	1 psi	¼ psi	270°	270°
PB	0 to 10 psi	1 psi	½ psi	270°	270°
WR	10 to 0" Water Vac.	2"	¼"	90°	–
WS	15 to 0" Water Vac.	3"	½"	90°	–
WT	40 to 0" Water Vac. & 75 mm Hg. Vac.	5" & 10 mm	1" & 1 mm	270°	180°
VD	5 to 10" Hg. Vac.	1"	¼"	270°	270°
VA	10 to 0" Hg. Vac.	2"	¼"	270°	270°
WW	10" Water Vacuum & 10" Water Pressure	2"	½"	180°	180°
WX	20" Water Vacuum & 40" Water Pressure	10"	1"	270°	270°
WY	10" Hg. Vacuum & 5 psi Pressure	2" & 1 psi	½" & .1 psi	270°	270°
WA	0 to 10" Water Press.	1"	¼"	90°	–
WB	0 to 15" Water Press.	3"	¼"	90°	90°
WH	0 to 20" Water Press. & 12oz.	½" & 1 oz.	1" & ¼ oz.	180°	90°
WI	0 to 30" Water Press. & 18oz.	5" & 1 oz.	½" & ½ oz.	215°	–
WI	0 to 30" Water Press. & 18oz.	10" & 1 oz.	1" & ½ oz.	–	180°
WJ	0 to 40" Water Press. & 24 oz.	5" & 3 oz.	1" & ½ oz.	270°	180°
WK	0 to 60" Water Press. & 35 oz.	10" & 5 oz.	1" & 1 oz.	270°	270°
WL	0 to 80" Water Press. & 45 oz.	10" & 5 oz.	1" & 1 oz.	270°	270°
WM	0 to 100" Water Press. & 57 oz.	10" & 5 oz.	1" & 1 oz.	270°	270°

BELLOWS AND SOCKET

CATALOG NO.	BELLOWS & SOCKET MATERIAL	DIAL SIZE	GAUGE TYPE	OPTIONAL CASE STYLE*	
				LOWER CONNECT	BACK CONNECT
BL14	Phsp. Brnz. Bellows Brass Socket	4½"	Low Pressure	#4 Aluminum Safety	#6 Aluminum Safety
BL44	316 SS Bellows 316 SS Socket				

*Extra cost.

HOW TO ORDER

B L 4 4 2 W K 4 L W ()

1. Basic 4-digit Catalog No. From Table Above _____
2. Polypropylene case style #2 (Standard) or choose from above table _____
3. Range Code From Range Tables Above _____
4. Thread Size: 4 = ¼ Npt Male; 2 = ½ Npt Male _____
5. Connection Location: L = Lower (Bottom); or R = Rear (Back) _____
6. Dial Color: W = White (Standard), B = Black (Optional) _____
7. If Any Gauge Options Are Desired – Specify Option Code(s) From Page 35 _____

kg/cm ²			
CODE	DUAL SCALE	CODE	SINGLE SCALE
MR	76-0 CMS & 30" VAC	E1	76-0 CMS
MZ	76 CMS/0/1 kg/cm ² & 30"-0-14 psi	EZ	76 CMS/0/1 kg/cm ²
MS	76 CMS/0/2 kg/cm ² & 30"-0-28 psi	E2	76 CMS/0/2 kg/cm ²
MT	76 CMS/0/4 kg/cm ² & 30"-0-57 psi	E3	76 CMS/0/4 kg/cm ²
MU	76 CMS/0/7 kg/cm ² & 30"-0-100 psi	E4	76 CMS/0/7 kg/cm ²
MV	76 CMS/0/10 kg/cm ² & 30"-0-140 psi	E5	76 CMS/0/10 kg/cm ²
MX	76 CMS/0/21 kg/cm ² & 30"-0-300 psi	E7	76 CMS/0/21 kg/cm ²
MA	0-1 kg/cm ² & 0-14 psi	EA	0-1 kg/cm ²
MB	0-2 kg/cm ² & 0-28 psi	EC	0-2 kg/cm ²
MC	0-4 kg/cm ² & 0-57 psi	EF	0-4 kg/cm ²
MD	0-7 kg/cm ² & 0-100 psi	EG	0-7 kg/cm ²
ME	0-11 kg/cm ² & 0-160 psi	EH	0-11 kg/cm ²
MF	0-14 kg/cm ² & 0-200 psi	EI	0-14 kg/cm ²
MQ	0-18 kg/cm ² & 0-250 psi	EJ	0-18 kg/cm ²
MG	0-21 kg/cm ² & 0-300 psi	EK	0-21 kg/cm ²
MH	0-28 kg/cm ² & 0-400 psi	EL	0-28 kg/cm ²
MP	0-35 kg/cm ² & 0-500 psi	EM	0-36 kg/cm ²
MI	0-42 kg/cm ² & 0-600 psi	EN	0-42 kg/cm ²
MJ	0-56 kg/cm ² & 0-800 psi	EO	0-56 kg/cm ²
MK	0-70 kg/cm ² & 0-1000 psi	EP	0-70 kg/cm ²
ML	0-105 kg/cm ² & 0-1500 psi	EQ	0-105 kg/cm ²
M2	0-140 kg/cm ² & 0-2000 psi	ER	0-140 kg/cm ²
MM	0-210 kg/cm ² & 0-3000 psi	ES	0-210 kg/cm ²
MN	0-350 kg/cm ² & 0-5000 psi	EU	0-350 kg/cm ²
MD	0-700 kg/cm ² & 0-10,000 psi	EV	0-700 kg/cm ²

kPa			
CODE	DUAL SCALE	CODE	SINGLE SCALE
L2	30" VAC & 100/0 kPa	K1	-100/0 kPa
L3	30"/0/15 psi & 100/0/100 kPa	K2	100/0/100 kPa
L4	30"/0/30 psi & 100/0/200 kPa	K3	100/0/200 kPa
L5	30"/0/60 psi & 100/0/400 kPa	K4	100/0/400 kPa
L6	30"/0/100 psi & 100/0/700 kPa	K5	100/0/700 kPa
L7	30"/0/150 psi & 100/0/1000 kPa	K6	100/0/1000 kPa
L8	30"/0/200 psi & 100/0/1400 kPa	K7	100/0/1500 kPa
LA	0-15 psi & 0-100 kPa	KA	0-100 kPa
LB	0-30 psi & 0-200 kPa	KB	0-200 kPa
LC	0-60 psi & 0-400 kPa	KC	0-400 kPa
LD	0-100 psi & 0-700 kPa	KO	0-700 kPa
LE	0-160 psi & 0-1000 kPa	KE	0-1000 kPa
LF	0-200 psi & 0-1400 kPa	KF	0-1400 kPa
LG	0-300 psi & 0-2100 kPa	KG	0-2000 kPa
LH	0-400 psi & 0-2800 kPa	KH	0-3000 kPa
LI	0-600 psi & 0-4200 kPa	KP	0-4000 kPa
LJ	0-800 psi & 0-5600 kPa	KI	0-5000 kPa
LK	0-1,000 psi & 0-7000 kPa	KZ	0-7000 kPa
LL	0-1,500 psi & 0-10,500 kPa	KJ	0-10,000 kPa
LM	0-2,000 psi & 0-14,000 kPa	KK	0-15,000 kPa
LN	0-3,000 psi & 0-21,000 kPa	KL	0-20,000 kPa
LO	0-5,000 psi & 0-35,000 kPa	KM	0-40,000 kPa
LP	0-10,000 psi & 0-70,000 kPa	KN	0-100,000 kPa

BAR			
CODE	DUAL SCALE	CODE	SINGLE SCALE
A1	30"/0 VAC & -1 bar	B2	-1/0 bar
A2	30"/0/15 psi & -1-0-1 bar	B3	-1/1.5 bar
A3	30"/0/30 psi & -1-0-2 bar	B4	-1/3 bar
A4	30"/0/60 psi & -1-0-4 bar	B5	-1/9 bar
A5	30"/0/100 psi & -1-0-7 bar	B6	-1/15 bar
A6	30"/0/150 psi & -1-0-10 bar	B9	-1/24 bar
A7	30"/0/200 psi & -1-0-14 bar	BA	0/1 bar
AC	0-15 psi & 0-1 bar	BB	0/1.6 bar
AD	0-30 psi & 0-2 bar	BC	0/2.5 bar
AE	0-60 psi & 0-4 bar	BD	0/4 bar
AF	0-100 psi & 0-7 bar	BE	0/6 bar
AG	0-160 psi & 0-11 bar	BF	0/10 bar
AH	0-200 psi & 0-14 bar	BG	0/16 bar
AJ	0-300 psi & 0-20 bar	BH	0/25 bar
AK	0-400 psi & 0-27 bar	BI	0/40 bar
AM	0-600 psi & 0-40 bar	BJ	0/60 bar
AO	0-800 psi & 0-56 bar	BK	0/100 bar
AP	0-1,000 psi & 0-70 bar	BL	0/160 bar
AR	0-1,500 psi & 0-100 bar	BM	0/250 bar
AS	0-2,000 psi & 0-140 bar	BN	0/400 bar
AT	0-3,000 psi & 0-200 bar	BO	0/600 bar
AV	0-5,000 psi & 0-350 bar	BP	0/1,000 bar
AY	0-10,000 psi & 0-700 bar	BQ	0/1,600 bar

EQUIVALENTS

1 kPa = 0.14504 psi
 1 bar = 14.5 psi = 100 kPa
 1 kg/cm² = 14.22 psi
 1 in. H₂O = 0.0361 psi
 1 cmHg = 0.1934 psi

EQUIVALENTS
CONVERSION FROM PSI:

1 psi = 6.8947 kPa
 1 psi = .06894 BAR
 1 psi = .07031 kg/cm²

CASE STYLE "Y"

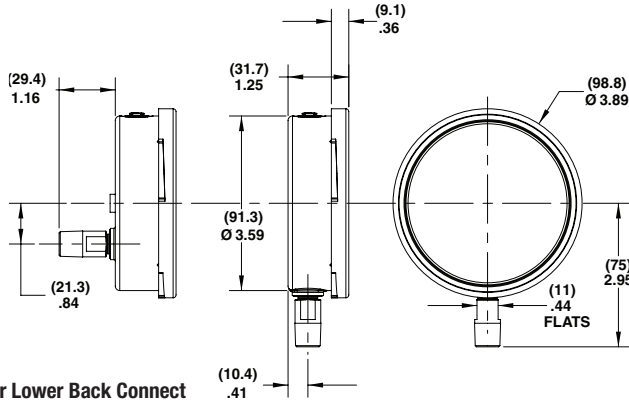

Stem Mount, Lower or Lower Back Connect

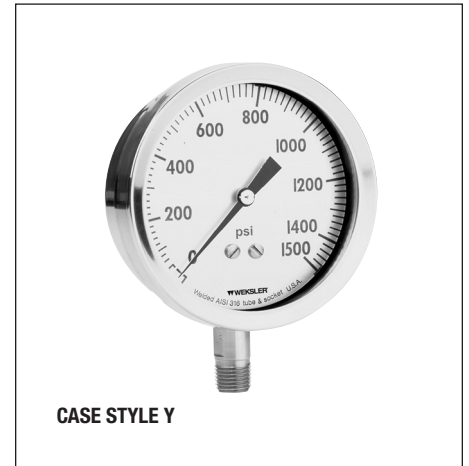

CASE STYLE "X"

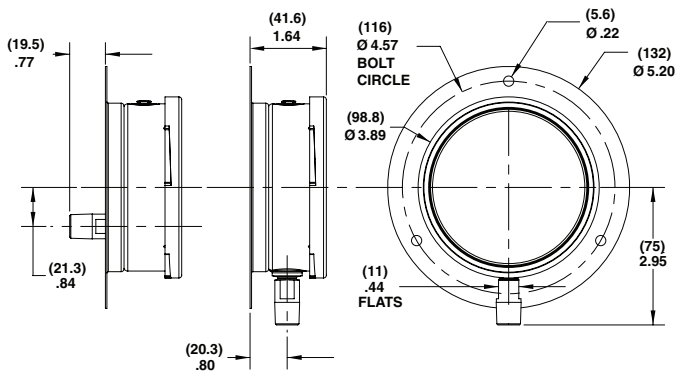

Stem Mount, Lower or Lower Back Connect With Back Flange

CASE STYLE "U"

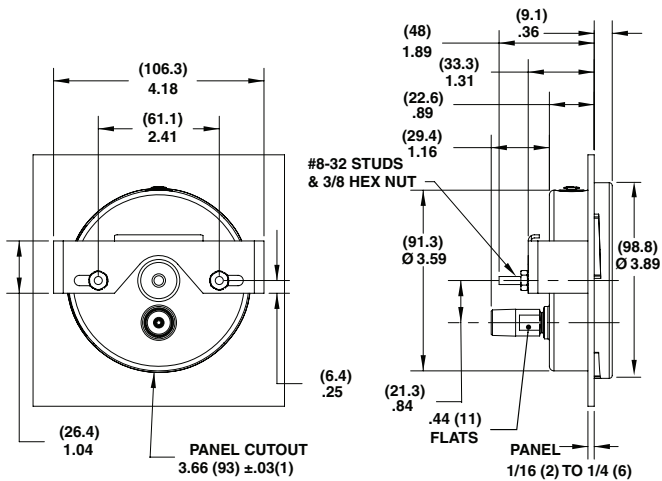

U-Clamp Panel Mount, Lower Back Connect

CASE STYLE "V"

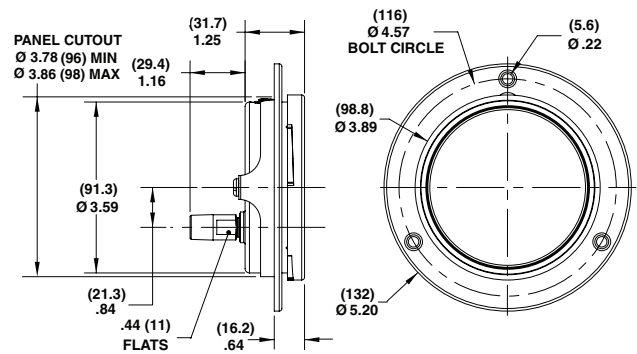

Flush Surface Mount, Lower Back Connect With Front Flange

Note: Dimensions in brackets () are millimeters.

CASE STYLE "2"

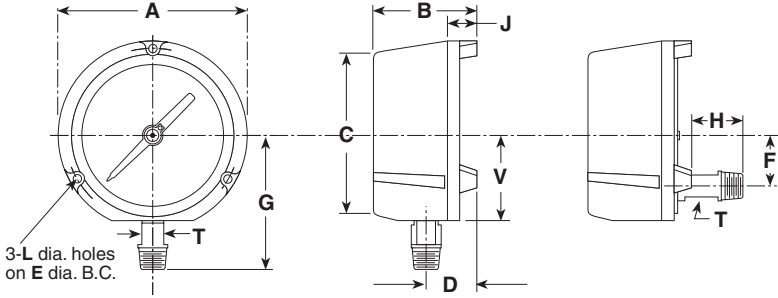

Surface Mount, Lower & Back Connect
Polypropylene Safety



Dial Size Inches	A	B	C	D	E	F	G	H	J	L	T	V	Weight (lbs)
4 1/2	5 1/16 (148)	3 3/8 (86)	5 1/16 (129)	1 1/8 (41)	5 3/8 (137)	1 1/8 (41)	3 1/16 (100)	3/4 (20)	1 (25)	(6)	5/8 (16)	2 5/8 (67)	2 1/2

CASE STYLE "4"

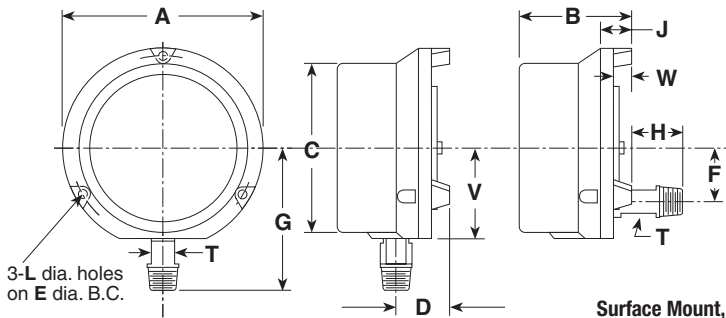

Surface Mount, Lower & Back Connect
Aluminum Safety



Dial Size Inches	A	B	C	D	E	F	G	H	J	K
4 1/2	5 1/16 (148)	3 1/8 (86)	4 7/8 (124)	1 1/8 (41)	5 3/8 (137)	1 1/8 (42)	3 1/16 (100)	7/8 (20)	1 1/16 (27)	—
6	7 7/16 (192)	3 1/2 (89)	6 5/8 (162)	1 5/8 (41)	7 (178)	1 1/2 (42)	4 1/2 (114)	—	—	—
8 1/2	10 1/16 (256)	2 7/8 (73)	4 3/4 (121)	1 1/16 (27)	9 5/8 (244)	1 3/8 (41)	6 (152)	1 3/8 (35)	—	1 1/16 (27)

Dial Size Inches	L	M	N	P	S	T	V	CC	LL	Wgt. (lbs)
4 1/2	.218	—	—	2 1/8 (54)	—	5/8 (16)	2 5/8 (67)	—	—	2 1/2
6	(6)	—	—	—	—	—	—	—	1/8-1/2 (3)(13)	3 3/8
8 1/2	—	9 (228)	3 3/8 (83)	—	1 1/16 (17)	—	—	#10-24	—	4 1/2

CASE STYLE "6"

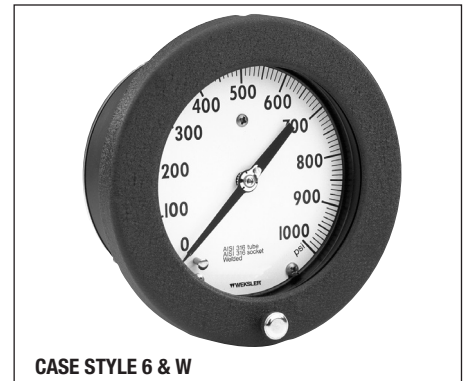
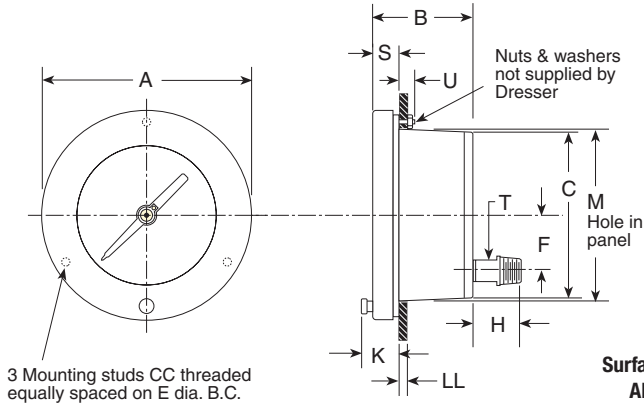

Dial Size Inches	A	B	C	E	F	H	K	M	P	S	T	U	CC	LL	Weight (lbs)
4 1/2	6 7/32 (148)			5 3/8 (137)				4 7/8 (124)					#10-24		2 1/2
6	7 9/16 (192)	2 7/8 (73)	4 3/4 (121)	7 (178)	1 5/8 (41)	1 1/8 (35)	1 1/16 (27)	6 1/2 (165)	2 1/8 (54)	5/8 (16)	5/8 (16)	3/4 (19)	1/4-20	1 5/8-1/2 (3)(13)	3



CASE STYLE "A"

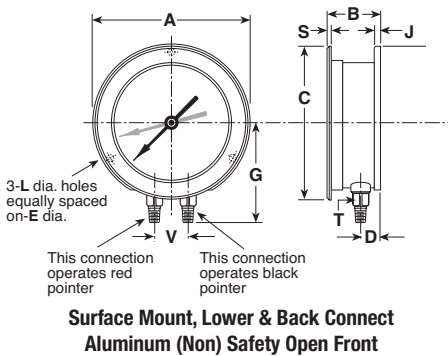

Dial Size Inches	A	B	C	D	E	G	I	J	L	V	AA	HH	Wght (lbs)
4 1/2	5 13/16 (148)	2 1/4 (57)	5 7/8 (149)	2 7/32 (22)	5 3/8 (137)	3 25/32 (96)	1 9/32 (15)	3/8 (10)	7/32 (6)	1 1/2 (38)	—	—	2.4 1.0 kg
6	7 11/16 (18)	2 5/8 (67)	6 9/32 (168)	1 5/16 (24)	7 (178)	4 15/16 (110)	5/8 (16)	3/16 (5)	9/32 (7)	1 5/8 (42)	—	—	3.6 1.6 kg

CASE STYLE "E"

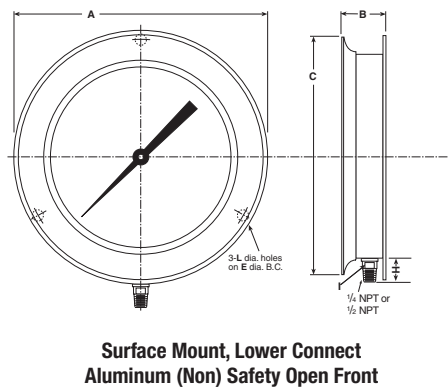

Dial Size Inches	A	B	C	D	E	G	J	K	L	M	S	Wgt (lbs)
12	14 1/2 (368)	2 15/16 (75)	14 1/4 (361)	1 1/2 (26)	13 1/2 (343)	7 1/2 (191)	3/16 (5)	—	.281 (7)	12 11/16 (329)	3/16 (5)	8 3.6 kg

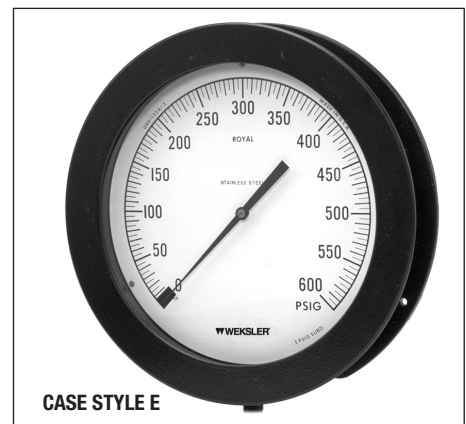

GAUGE ACCESSORIES

Accessories/Options/Tools.....	31-33
Snubbers	34
Gauge Cocks, Needle Valves, Siphons	35

THROTTLING DEVICES

A throttling device should be used when a pressure gauge is subjected to rapid pressure fluctuations, which make the gauge difficult to read because of rapid pointer movement. Such a device reduces pressure impact, slows the speed and range of pointer movement, and prolongs gauge life.

Throttling effect is obtained by installing a restricting orifice between the gauge socket connection and the bourdon tube. Several types are available: throttle screws, pressure snubbers, pulsation dampeners.

Severe service applications are characterized by the presence of significant levels of pressure pulsation and/or vibration. Gauges should be protected from severe pressure pulsation by the inclusion of a dampener such as a throttle plug/screw or porous metal snubber. If the pulsation is extreme, a liquid-filled gauge, with dampener, should be used. A liquid-filled gauge will also last significantly longer than a comparable dry gauge when vibration is present. If the vibration levels are extreme, the only solution may be to remotely mount the gauge away from the source of vibration. In that case capillary tubing may be used to connect the gauge to the pressure source.

THROTTLE SCREWS

The simplest means of providing a restriction in the socket, a throttle screw, should be ordered with the gauge. Threaded or pressed into an instrument socket, the throttle screw orifice selected is based on the viscosity of the pressure fluid, rapidity of pressure fluctuations, and the amount of dampening effect desired.

A smaller orifice should be used for

low viscosities, high frequencies, high pressure and reduced pointer amplitude. To accommodate these variables, throttle screws are available in these sizes: 0.0135, 0.020, 0.031, 0.040, and 0.070 inches, in brass and stainless steel.

When orifice size or service condition is not specified, a 0.020-inch orifice will be supplied on Royal pressure gauges 0.0135, on 3½" Regal Gauges.

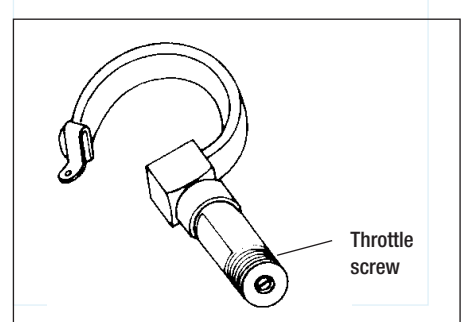

STATIONARY RED SET HAND



Stationary Red Set Hand to indicate a specific pressure. Ring must be removed to move the hand.

OVERLOAD STOP

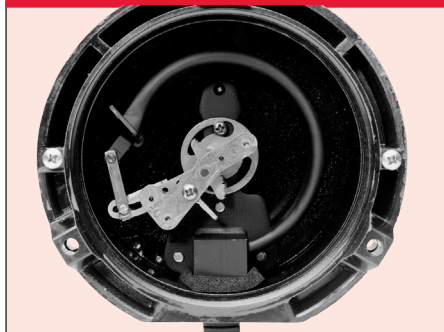

Overload Stop to protect gauge system against extreme overpressure.

SPECIAL DIAL



Special Dial ranges different from standards, or custom artwork, available on application.

MAXIMUM POINTER



Maximum Pointer available for gauges 4½" size and larger. Indicates maximum pressure attained. Can be reset by a knob on outside of window.

VACUUM STOP



Vacuum Stop to protect low range gauges against vacuum.

OPTIONAL WINDOWS

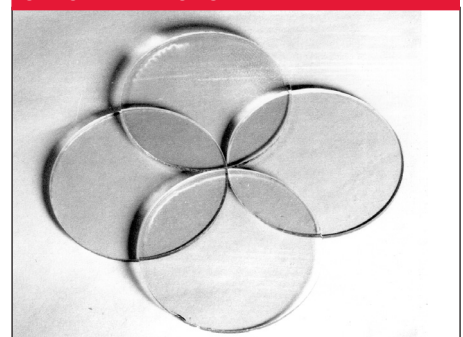

Plastic Disc – optional for glass window
Laminated Safety Glass – optional for glass window
Nonglare Glass – optional for glass window

ELECTRIC WARNING CONTACTS

The electric contact feature is a switching mechanism actuated by the indicating pointer. Switch points are adjustable and can be set throughout the 270° arc. Contacts are used to activate alarms and relays. (Not recommended for continuous switching). The Weksler electric contact is an ideal accessory to turn on a signal light, sound an alarm, or operate a pump or valve. The contacts can easily be set so that a circuit can be closed or opened at a desired pressure. Settings can be easily made in the field without removing the instrument from service. Contact adjustment is made externally with a removable key to make the instrument virtually tamper proof. Contacts are equipped with adjustable magnets to eliminate chatter caused by vibration. A plug-in connector with five feet of electrical cable is standard.

STANDARD FEATURES

- High impact polycarbonate enclosure for ambient temperature up to 150°F
- Full scale contact adjustment from front of enclosure
- Available on ranges 30 psi and up
- Magnetically assisted, silver alloy contact
- Accuracy $\pm 2\%$ of scale arc (add to instrument accuracy)
- Rated for $\frac{1}{4}$ amp. 110 volt AC non-inductive load
- Available in: 4½" case styles #2*, #4, #6, "A"
6" case styles #2, #4, #6, "A"

Model	Code	Contact arrangements
2265	XED	High and low contact
	XEE	Double high contact
	XEF	Double low contact
	XEG	"OFF" at low and high, and "ON" in between

* Style case #2 with lower connect comes with DIN Connection. No cable, mating connector available at extra charge.



Indicating accuracy of Royal Gauge, above 300 psi with contact:
 Pointer not carrying contact – 1.0%.
 Pointer carrying contact – 1.5%.
 For ranges below 30 psi, add an additional ½% to indicating accuracies.

TEST GAUGE CARRYING CASE

This rugged blow-molded high-density polyethylene carrying case accommodates the standard 4½", 6" & 8½" Regal analog test gauges. It accepts both lower and back connect gauges. A foam insert protects the gauge when not in use. Type No. 2505.



ROYAL AND REGAL GAUGE OPTIONS

CODE	DESCRIPTION
XNN	Paper Tag on Gauge
XNH	SS Tag Wired to Gauge
XMN	SS Tag Wired to Gauge
XOS ⁽¹⁾	Overload Stop
XVS ⁽¹⁾	Underload Stop
XTS	Throttle Screw
XDM	Dial Markings
X6B	Cleaned for Oxygen Service
XGV	Silicone Filled
XSH	Red Set Hand
XSJ	Dual Red Set Hands
XEP*	Max. Indicating Hand
XEQ*	Min. Indicating Hand
XSG	Safety Glass
XPD	Plastic Window
XC1	Certificate of Conformance
XC4	Calibration Certificate
* Not available in 3½" Regal	

(1) Standard for 3½

TYPE 1278M FLUSH MOUNTING RING

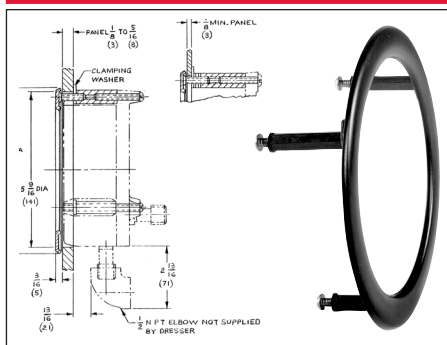

Gauge Size (inches)	Ring O.D. (inches)	A Dia. (inches)	"B"-Three Screws
			Size
4½	6.000	5.625	#10-24 x 1½"
67.765	7.25	¼-20 x 1½"	

Used to flush-mount 4½" and 6" Royal and bellows type gauges. Standard finish is black; polished stainless steel finish is available at an extra charge, 4½" and 6".

FLUSH MOUNTING RING

CODE	DESCRIPTION	TYPE	MOUNTING MATERIAL
56	Flush Mounting Rings*	1278M	Black
57		1278MC	Polished SS

*For 4½" and 6" Royal / Regal gauges manufactured after 10/1/04

TYPE A-1285

Ring Wrench – 4½"

(For installing front threaded rings in 4½" #2, #4 safety cases)

TYPE A-1286

Ring Wrench – 6"

(For installing front threaded rings in 6" #4 aluminum safety cases)

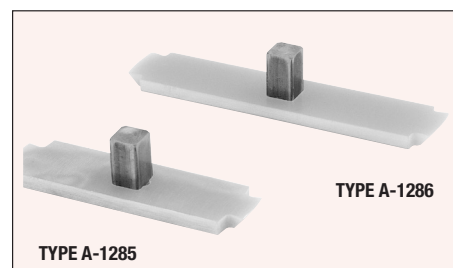

FILTER TYPE

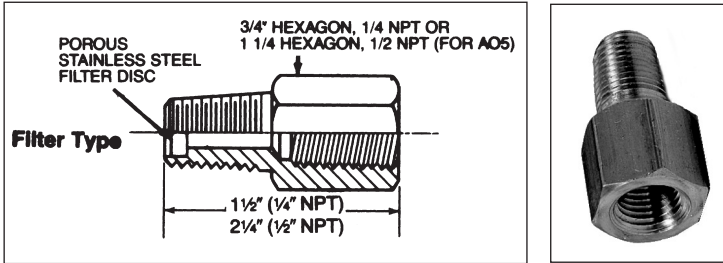

Filter Type: Snubbing element consists of a $\frac{3}{8}$ " diameter x $\frac{1}{8}$ " thick Micro Metallic stainless steel filter. When placed in the line just before the pressure gauge, the gauge pointer moves across the scale at a rate which is proportional to the pressure differential across the snubber element.

TYPE NUMBER	GAS OR LIQUID IN PIPE LINE	PRESSURE RANGE	CONNECTION	MATERIAL
BW 41 BW 42 BW 43	Air Water-Light Oil Heavy Oil	1,500 psi	1/4 NPT	Brass
SW 41 SW 42 SW 43	Air Water-Light Oil Heavy Oil	5,000 psi	1/4 NPT	SS
A05D A05E	Heavy Oil Water Light Oil	15,000 psi	1/2 NPT	SS

PISTON TYPE

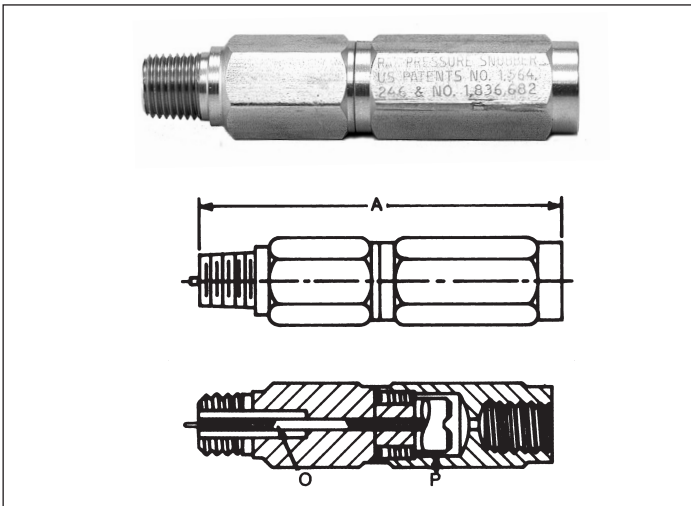

Piston Type: Shocks and pulsations are absorbed in the doughnut-shaped orifice (O) formed by the piston (P) in the tube. As the piston moves up and down with the pulsation, it automatically clears away any sediment or pipe scale that would clog a simple orifice or needle valve.

Each snubber is furnished with three pistons. The snubbing may be changed to suit individual installations by changing pistons. By using the proper piston, any of the listed snubbers can be made to operate satisfactorily from vacuum to its maximum rated pressure on any fluid compatible with the body material. These snubbers may be installed vertically, horizontally, inverted, or at any angle.

TYPE NUMBER	GAS OR LIQUID IN PIPE LINE	PRESSURE RANGE LBS.	PIPE SIZE AND LENGTH	MATERIAL
RS1	Air, water, steam, etc.	0-3000	1/4 NPT	Brass
RS7	Thin corrosive liquid, gases	0-5,000	A = 3 1/2"	SS
RS8	Thick corrosive liquids		1/2 NPT	Brass
RS6	Oil, water, etc.	0-10,000	A = 3 5/8"	SS
RS9	Thin or thick corrosive			

ADJUSTABLE SNUBBER



MODEL	MAX. WORKING PRESS.	BODY MATERIAL	LENGTH O.A.	THREAD LENGTH	THREAD SIZE
MSB4	3,000	Brass	1.60	.50	1/4 NPT
MSB2	3,000	Brass	2.28	.80	1/2 NPT
MSS4	5,000	316SS	1.60	.50	1/4 NPT

NOTE: The adjusting screw, ball and ball retainer are Stainless Steel, Buna N Seals are standard. Teflon, Viton and Butyl Seals are available.

Adjustable Snubber

The Universal Adjustable Snubber has a ball check cut-off to block line surges, shock waves and fluid hammer; and an adjustable fine thread choke valve to tune out line pulsations. The combination of the ball cut-off and a tunable choke valve makes it an all-purpose, universal Snubber that is used on low displacement instruments such as bourdon tube gauges which require heavy dampening; and with high displacement instruments such as diaphragm, piston and bellows operated gauges, recorders and controllers, which require moderate to heavy dampening.

The adjustable choke valve is also used as a positive shut-off valve, to isolate the gauge or instrument, for servicing or replacement.

The operation of the Adjustable Snubber cut-off ball and the choke valve is shown in the chart. The cut-off ball blocks and clamps off shock and hammer transients in the line, which are above the normal pressure level in the system. The choke valve throttles and dampens out pulsations and cyclic pressure waves, and may be adjusted to dampen out to any level desired to prevent pointer oscillation on gauges, chart painting on recorders, instability in controllers or, damage to instruments, generally.

Gauge Cocks Needle Valves Siphons

BRASS GAUGE COCKS

TYPE NO.	TYPE	CONNECTIONS	MAXIMUM PRESSURE
A10	Tee Handle - Brass	¼" Female	125 psi
A10E	Heavy Duty Tee Handle	¼" Female	200 psi
A11	Lever Handle - Brass	¼" Male and Female	200 psi
A12	Lever Handle - Brass	¼" Female	200 psi
A20	Tee Handle - Brass	½" Female	200 psi

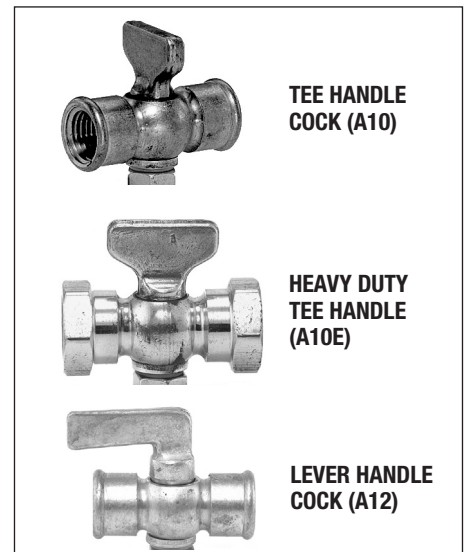

BAR STOCK NEEDLE VALVES

These valves are used primarily to closely regulate fine flow. However, they may be used as a throttling device on lines where rapid and excessively pulsating pressures would tend to effect the gauge performance or mechanism.

TYPE NO.	SIZE	MATERIAL	PRESSURE & TEMP. RATING
BBV4	¼ NPT	Brass: For oil, water, gas, etc.	600 psi @ 300°F
SSV4	¼ NPT	303 Stainless Steel: For oil, water, gas, etc.	5000 psi @ 500°F
AV32	½ NPT	Bronze: For oil, water, gas, etc.	500 psi @ 150°F
AV44	¼ NPT	Carbon Steel: Parkerized and Parcolaced, for resistance to corrosion	475 psi @ 1,000°F 550 psi @ 900°F 600 psi @ 850°F 10,000 psi @ 150°F
AV74	¼ NPT	316 Stainless Steel provides greatest overall resistance to corrosion; very good for sub-zero service.	4,000 psi @ 150°F

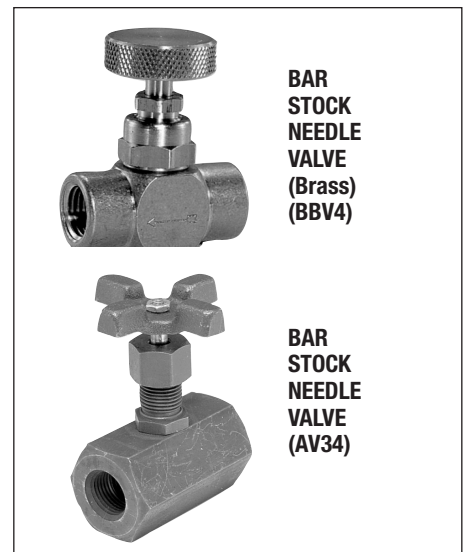

SIPHONS

When a gauge is to be used for steam pressures, a siphon filled with water is recommended between the line and gauge to prevent high temperature steam from entering the gauge bourdon tube.

TYPE NO.	SIZE	SIPHON MATERIAL	CAPACITY
A03I	¼ NPT	Iron (Schedule 40)	500 psi and 400°F
A03B		Brass	250 psi and 400°F
CPS4		Seamless Steel, extra heavy (Schedule 80)	1,000 psi and 850°F
CPSS4		Seamless Stainless Steel XH (Schedule 80)	2,000 psi and 1000°F
CPS2	½ NPT	Steel (Schedule 80)	1,000 psi and 850°F
CPSS2		Seamless Stainless Steel XH (Schedule 80)	2,000 psi and 1000°F



GAUGE TOOLS — **Hand Jack:** for removing pointer. Specify Type A01. **Hand Set:** for installing pointer. Specify Type A02

ECONOMY UTILITY GAUGES

Dry Gauges	39
Liquid Filled Gauges	40-42
Contractor Gauges	43



Dry Gauges, Steel Case, Bronze Tube, Brass Socket, ±3-2-3% of Span Accuracy

STANDARD FEATURES

- Available in 1½", 2", 2½" and 3½" sizes
- Black finish steel case and ring with plastic window
- Panel gauge case is black finish steel with studs and chrome-plated ring.
- Panel mount gauges available in 1½", 2" and 2½" sizes, contact factory, NA for all models.
- ½ NPT lower and back connection available 1½" size; ¼ NPT lower and back connection available in 2" and 2½" sizes; ¼ NPT lower connection available in 3½" size
- Dual scale dials with bar/kPa in blue (inner scale); psi in black (outer scale); on white background



CATALOG NUMBERS

Dial Size	1½"		2"		2½"		3½"
Connection Location	Back	Bottom	Back	Bottom	Back	Bottom	Bottom
Connection NPT	½	½	¼	¼	¼	¼	¼
Range (psi/bar/kPa)							
307/0 vac. and -1/0 bar (-100/0 kPa)	UA15H8C	UA15H8L	UA20H4C	UA20H4L	UA25H4C	UA25H4L	UA35H4L
307/0/30 psi and -1/0/2 bar (-100/0/200 kPa)	-	-	UA20J4C	UA20J4L	-	UA25J4L	UA35J4L
307/0/60 psi and -1/0/4 bar (-100/0/400 kPa)	-	-	-	UA20K4L	-	UA25K4L	UA35K4L
0-15 psi and 1 bar (100 kPa)	UA15N8C	UA15N8L	UA20N4C	UA20N4L	UA25N4C	UA25N4L	UA35N4L
0-30 psi and 2 bar (200 kPa)	UA15A8C	UA15A8L	UA20A4C	UA20A4L	UA25A4C	UA25A4L	UA35A4L
0-60 psi and 4 bar (400 kPa)	UA15B8C	UA15B8L	UA20B4C	UA20B4L	UA25B4C	UA25B4L	UA35B4L
0-100 psi and 7 bar (700 kPa)	UA15C8C	UA15C8L	UA20C4C	UA20C4L	UA25C4C	UA25C4L	UA35C4L
0-160 psi and 11 bar (1100 kPa)	UA15D8C	UA15D8L	UA20D4C	UA20D4L	UA25D4C	UA25D4L	UA35D4L
0-200 psi and 14 bar (1400 kPa)	UA15E8C	UA15E8L	UA20E4C	UA20E4L	UA25E4C	UA25E4L	UA35E4L
0-300 psi and 21 bar (2100 kPa)	-	-	UA20F4C	UA20F4L	UA25F4C	UA25F4L	UA35F4L
0-600 psi and 42 bar (4200 kPa)	-	-	-	UA20G4L	-	UA25G4L	UA35G4L

To order: specify the "catalog number" from table above. For panel mount gauges (back connection only) add "-UC" to the 7 digit catalog number. (NOT ALL MODELS ARE AVAILABLE AS PANEL MOUNT).

GUAGE DIMENSIONS UA15, UA20, UA25, UA35

Lower Connection Gauge Size/Type		A	B	C	D		E	F
					½	¼		
UA15	Inch	1.66	0.99	1.45	0.33	-	0.32	1.61
	mm	42	25	37	8	-	5	41
UA20	Inch	2.08	1.13	1.80	-	0.37	0.39	2.01
	mm	53	28	46	-	9	10	51
UA25	Inch	2.48	1.13	1.95	-	0.42	0.39	2.43
	mm	63	29	50	-	11	10	62
UA35	Inch	3.47	1.16	2.68	-	0.46	0.43	3.42
	mm	88	29	68	-	12	11	87
Back Connection Gauge Size/Type		A	B	E	F	G	H	
UA15	Inch	1.66	.99	0.31	1.61	1.56		½
	mm	42	25	8	41	40		
UA20	Inch	2.08	1.13	0.39	2.01	1.85		¼
	mm	53	29	10	51	47		
UA25	Inch	2.48	1.13	0.39	2.44	1.87		¼
	mm	63	29	10	62	47		

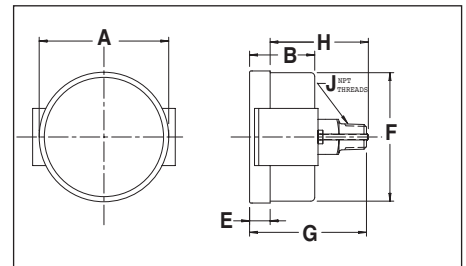
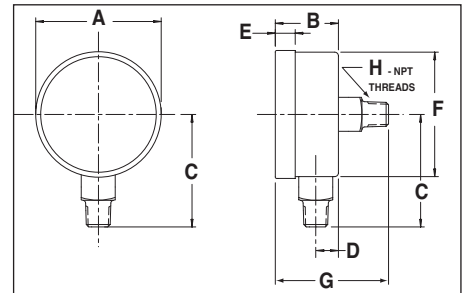

GUAGE DIMENSIONS UA15-UC, UA20-UC, UA25-UC

Back Connection Gauge Size/Type		A	B	E	F	G	H	J
UA15	Inch	1.78	1.00	0.20	1.62	1.60	1.24	½
	mm	45	25	5	41	41	31	
UA20	Inch	2.20	1.10	0.18	2.01	1.81	1.59	¼
	mm	56	28	4	51	46	40	
UA25	Inch	2.62	1.15	0.23	2.47	1.83	1.67	¼
	mm	66	29	6	63	46	42	

PANEL CUT-OUT

Panel Cut-Out	Hole Diameter		Max. Panel Thickness
	Minimum Inches (mm)	Maximum Inches (mm)	
1½" Gauge	1.615	1.665	½"
2" Gauge	2.035	2.095	7/16"
2½" Gauge	2.462	2.538	7/16"

STANDARD FEATURES

- Available in 40mm, 50mm, 63mm and 100mm sizes
- Stainless steel case and ring with plastic window
- 1/8" NPT back connection available in 40mm size; 1/4" NPT lower and back connection available in 50mm and 63mm sizes; 1/2" NPT lower connection available in 100mm size
- Dual scale dials with bar/kPa in blue (inner scale); psi in black (outer scale); on white background
- Panel mount kits available



CATALOG NUMBERS

Dial Size	40mm	50mm		63mm		100mm
Connection Location	Back	Back	Bottom	Back	Bottom	Bottom
Connection NPT	1/8"	1/4"	1/4"	1/4"	1/4"	1/2"
Range (psi/bar/kPa)						
30"/0 vac. and -1/0 bar (-100/0 kPa)	BY10YVC8CW	—	—	BY12YVC4CW	BY12YVC4LW	BY14YVC4LW
30"/0/30 psi and -1/0/2 bar (-100/0/200 kPa)	—	—	—	BY12YCB4CW	BY12YCB4LW	—
30"/0/60 psi and -1/0/4 bar (-100/0/400 kPa)	—	—	—	—	BY12YCC4LW	BY14YCC4LW
30"/0/150 psi and -1/0/10 bar (-100/0/1000 kPa)	—	—	—	BY12YCE4CW	BY12YCE4LW	—
30"/0/300 psi and -1/0/10 bar (-100/0/2000 kPa)	—	—	—	BY12YPC4CW	BY12YPC4LW	—
0-15 psi and 1 bar (100 kPa)	BY10YPD8CW	—	BY11YPD4LW	BY12YPD4CW	BY12YPD4LW	BY14YPD4LW
0-30 psi and 2 bar (200 kPa)	BY10YPE8CW	—	BY11YPE4LW	BY12YPE4CW	BY12YPE4LW	BY14YPE4LW
0-60 psi and 4 bar (400 kPa)	BY10YPE8CW	BY11YPE4CW	BY11YPE4LW	BY12YPE4CW	BY12YPE4LW	BY14YPE4LW
0-100 psi and 7 bar (700 kPa)	BY10YPF8CW	BY11YPF4CW	BY11YPF4LW	BY12YPF4CW	BY12YPF4LW	BY14YPF4LW
0-160 psi and 11 bar (1100 kPa)	BY10YPG8CW	BY11YPG4CW	BY11YPG4LW	BY12YPG4CW	BY12YPG4LW	BY14YPG4LW
0-200 psi and 14 bar (1400 kPa)	—	—	—	BY12YPH4CW	BY12YPH4LW	—
0-300 psi and 21 bar (2100 kPa)	BY10YPJ8CW	—	—	BY12YPJ4CW	BY12YPJ4LW	BY14YJP4LW
0-600 psi and 42 bar (4200 kPa)	—	—	—	BY12YPM4CW	BY12YPM4LW	—
0-1000 psi and 0/70 bar (7000 kPa)	—	—	—	BY12YPP4CW	BY12YPP4LW	—
0-2000 psi and 0/140 bar (14,000 kPa)	—	—	—	BY12YPS4CW	BY12YPS4LW	—
0-3000 psi and 0/210 bar (21,000 kPa)	BY10YPT8CW	—	—	BY12YPT4CW	BY12YPT4LW	BY14YPT4LW
0-5000 psi and 0/350 bar (35,000 kPa)	—	—	—	BY12YPV4CW	BY12YPV4LW	—
0/10,000 psi and 0/700 bar (70,000 kPa)	—	—	—	BY12YPY4CW	BY12YPY4LW	—

To order: specify 10-digit "catalog number" from above table. For panel mount gauges (back connection only) add "-UC" to 10-digit catalog number. (NOT ALL MODELS ARE AVAILABLE AS PANEL MOUNT)

GAUGE DIMENSIONS BY10Y, BY11Y, BY12Y, BY14Y

Lower Connection Gauge Size/Type		A	B	C	D-1/4"	E	F	
50 mm	BY11Y	Inch	2.21	1.11	1.86	0.37	0.19	2.01
		mm	56	28	47	9	5	51
63 mm	BY12Y	Inch	2.62	1.13	2.08	0.39	0.22	2.45
		mm	66	29	53	10	5	75
100 mm	BY14Y	Inch	4.29	1.42	3.14	0.46	0.29	3.88
		mm	109	36	80	12	7	98
Back Connection Gauge Size/Type		A	B	F	G	H		
40 mm	BY10Y	Inch	1.78	1.00	1.61	1.62	1/8"	
		mm	45	25	41	41		
50 mm	BY11Y	Inch	2.21	1.11	2.02	2.05	1/4"	
		mm	56	28	51	52		
63 mm	BY12Y	Inch	2.62	1.13	2.45	2.05	1/4"	
		mm	66	29	62	52		

PANEL MOUNT ASSEMBLY DIMENSIONS FOR 40mm, 50mm, 63mm GAUGES

Part No.		A	B	C	D	E	F	G	H	J	K
40mm Clamp	Inch	2.36	1.02	189	0.45	0.44	0.94	0.94	0.20	0.10	M5X0.8
	mm	60	26	48	11.6	11.3	24	24	5	2.50	M5X0.8
50mm Clamp	Inch	2.83	1.26	236	0.57	0.56	0.47	1.18	0.24	0.10	M5X0.8
	mm	72	32	60	14.6	14.2	30	72	6	2.50	M5X0.8
63mm Clamp	Inch	3.27	1.26	280	0.57	0.56	0.47	1.40	0.24	0.10	M5X0.8
	mm	83	32	71	14.6	14.2	12	35.5	6	2.50	M5X0.8

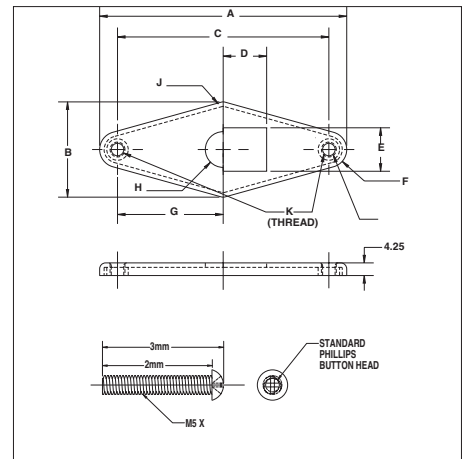
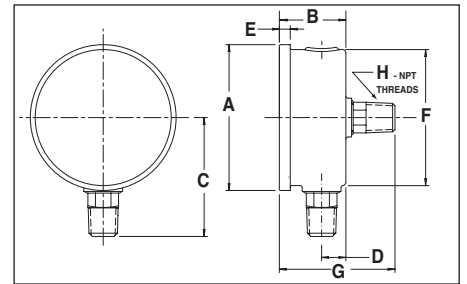

PANEL MOUNT PART NUMBER

ITEM - NO.
U-clamp 40
U-clamp 50
U-clamp 63

STANDARD FEATURES

- Available in 40mm, 50mm, 63mm and 100mm sizes
- Stainless steel case and ring with plastic window
- 1/8" NPT back connection available in 40mm size; 1/4" NPT lower and back connection available in 50mm and 63mm sizes; 1/2" NPT lower connection available in 100mm size
- Dual scale dials with bar/kPa in blue (inner scale); psi in black (outer scale); on white background
- Panel mount kits available



CATALOG NUMBERS

Dial Size	40mm	50mm	63mm	100mm
Connection Location	Back	Back	Bottom	Bottom
Connection NPT	1/8"	1/4"	1/4"	1/2"
Range (psi/bar/kPa)				
30"/0 vac. and -1/0 bar (-100/0 kPa)	—	—	BY42YVC4CW	BY42YVC4LW
30"/0/30 psi and -1/0/2 bar (-100/0/200 kPa)	—	—	BY42YCB4CW	BY42YCB4LW
30"/0/60 psi and -1/0/4 bar (-100/0/400 kPa)	—	—	BY42YCC4CW	BY42YCC4LW
30"/0/150 psi and -1/0/10 bar (-100/0/1000 kPa)	—	—	BY42YCE4CW	BY42YCE4LW
30"/0/300 psi and -1/0/10 bar (-100/0/2000 kPa)	—	—	BY12YPC4CW	BY12YPC4LW
0-15 psi and 1 bar (100 kPa)	—	—	—	BY42YPC4LW
0-30 psi and 2 bar (200 kPa)	BY40YPD8CW	BY41YPD4CW	—	BY42YPD4CW
0-60 psi and 4 bar (400 kPa)	BY40YPE8CW	BY41YPE4CW	—	BY42YPE4CW
0-100 psi and 7 bar (700 kPa)	—	BY41YPF4CW	—	BY42YPF4CW
0-160 psi and 11 bar (1100 kPa)	BY40YPG8CW	BY41YPG4CW	—	BY42YPG4CW
0-200 psi and 14 bar (1400 kPa)	—	—	—	BY42YPH4CW
0-300 psi and 21 bar (2100 kPa)	—	BY41YPJ4CW	—	BY42YPJ4CW
0-600 psi and 42 bar (4200 kPa)	—	—	—	BY42YPM4CW
0-1000 psi and 0/70 bar (7000 kPa)	—	—	—	BY42YPP4CW
0-2000 psi and 0/140 bar (14,000 kPa)	—	—	—	BY42YPS4CW
0-3000 psi and 0/210 bar (21,000 kPa)	—	—	—	BY42YPT4CW
0-5000 psi and 0/350 bar (35,000 kPa)	—	—	—	BY42YPV4CW
0/10,000 psi and 0/700 bar (70,000 kPa)	—	—	—	BY42YPY4CW

To order: specify 10-digit "catalog number" from above table. For panel mount gauges (back connection only) add "-UC" to 10-digit catalog number.

GAUGE DIMENSIONS BY40Y, BY41Y, BY42Y, BY45Y

Lower Connection Gauge Size/Type		A	B	C	D-1/4"	E	F	
50 mm	BY41Y	Inch	2.21	1.11	1.86	0.37	2.01	
		mm	56	28	47	9	51	
63 mm	BY42Y	Inch	2.70	1.26	2.42	0.42	2.45	
		mm	68.50	32	61.50	10.6	62.20	
100 mm	BY45Y	Inch	4.15	1.61	3.40	0.73	3.90	
		mm	105.30	40.90	86.40	18.50	99.10	
Back Connection Gauge Size/Type		A	B	F	G	H		
40 mm	BY40Y	Inch	1.78	1.00	1.61	1.62	1/8"	
		mm	45	25	41	41		
50 mm	BY41Y	Inch	2.21	1.11	2.02	2.05	1/4"	
		mm	56	28	51	52		
63 mm	BY42Y	Inch	2.70	1.26	2.45	1.87	1/4"	
		mm	68.50	32	62.20	47.50		

PANEL MOUNT ASSEMBLY DIMENSIONS FOR 40mm, 50mm, 63mm GAUGES

Part No.	A	B	C	D	E	F	G	H	J	K
40mm Clamp	Inch	2.36	1.02	189	0.45	0.44	0.94	0.94	0.20	0.10
	mm	60	26	48	11.6	11.3	24	24	5	2.50
50mm Clamp	Inch	2.83	1.26	236	0.57	0.56	0.47	1.18	0.24	0.10
	mm	72	32	60	14.6	14.2	30	72	6	2.50
63mm Clamp	Inch	3.27	1.26	280	0.57	0.56	0.47	1.40	0.24	0.10
	mm	83	32	71	14.6	14.2	12	35.5	6	2.50

PANEL MOUNT PART NUMBER

ITEM - NO.
U-clamp 40
U-clamp 50
U-clamp 63

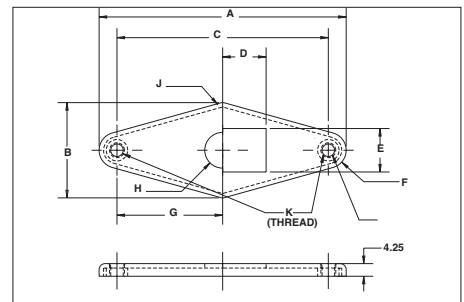
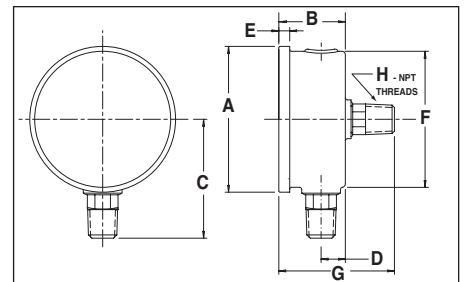

STANDARD FEATURES

- 4 1/2" diameter
- Corrosion Resistant Stainless Steel Case and Ring, Plastic Lens.
- Zero adjusting screw.
- Soft soldered phosphor bronze tube with brass socket. Suitable for steam, water, air, oil, gas or any medium not corrosive to copper alloys.
- Bronze/brass movement.
- Easy to read dial; white background with bold black numerals and graduations, 270° arc.
- 1/4 NPT bottom connection only.

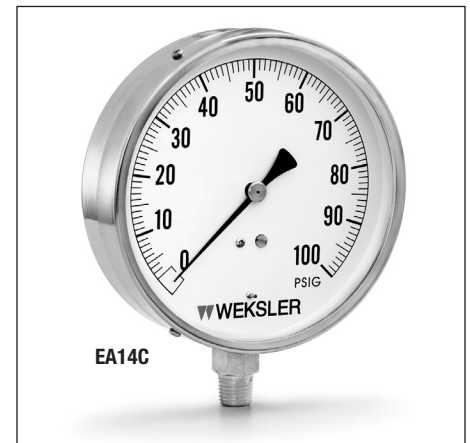
PRESSURE RANGES

CATALOG NO	DIAL RANGES	FIGURE INTERVALS	SMALLEST GRADUATION
EA14A	0- 30 psi	5 psi	1/2 psi
EA14B	0- 60 psi	10 psi	1 psi
EA14C	0-100 psi	10 psi	1 psi
EA14D	0-160 psi	20 psi	2 psi
EA14E	0-200 psi	20 psi	2 psi
EA14F	0-300 psi	50 psi	5 psi
EA14G	0-500 psi	50 psi	5 psi

VACUUM RANGES

EA14H	30"-0 Hg. Vac	5 in.	1/2 in.
-------	---------------	-------	---------

COMPOUND RANGES

EA14J	30"-0- 30 psi	10" & 5 psi	1" & 1 psi
EA14K	30"-0-100 psi	15" & 10 psi	5" & 1 psi
EA14L	30"-0-150 psi	30" & 25 psi	5" & 5 psi

TO ORDER: SPECIFY 5 DIGIT "CATALOG NUMBER" FROM ABOVE TABLE.

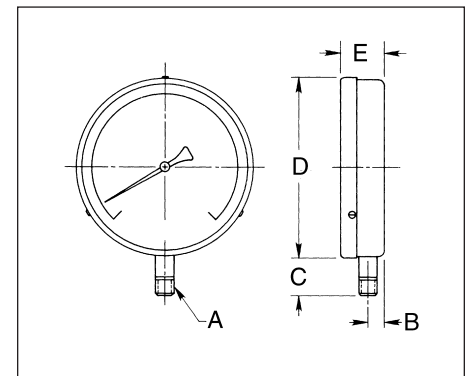
DIMENSIONS

GAUGE DIMENSIONS – EA14C

A	B	C	D	E
1/4 NPT	7/16	1 1/16	4 15/16	1 3/16
	(11)	(27)	(126)	(30)

BIMETAL THERMOMETERS

Introduction	45
Adjustable Angle	46
3" Dial Size – Rigid Forms.....	47
5" Dial Size – Rigid Forms.....	48
3" Dial Size – Heavy Duty.....	49
Pocket Bimetal.....	50
Standard Threaded Thermowell.....	51



RANGE

Standard Fahrenheit and Celsius ranges have been established to encompass all normal temperature measurement requirements. A thermometer can be used at an operating temperature anywhere throughout its range. Although no bimetal thermometer should be exposed continuously to a process temperature over 800 °F.

DIAL SIZE

Select a dial size that allows you to comfortably read the dial from the normal distance when installed.

ACCURACY

All Weksler BiMetal Thermometers have an accuracy of $\pm 1\%$ of span. For accurate readings stem must be immersed at least 2 inches in liquids and 4 inches in gases.

UNDER/OVER RANGE PROTECTION

Temporary exposure to temperatures under or over 50% of the full-scale range will not impair accuracy (up to 500°F or 260°C maximum).

CASE ASSEMBLY

The case, bezel, stem and fittings are stainless steel (300 series). The head assembly is sealed to exclude dirt, dust and moisture on 3" and 5" dial sizes, all joints are welded.

DIALS

Dials are white with clear black graduations and numerals and are easy to read.

FACE

A gasketed glass window is standard on 3" and 5" dial sizes. Where breakage is a concern, a plastic or shatterproof glass window is optional at extra cost. On 1" and 2" dial sizes a plastic window is standard (no options available). Plastic windows are not suitable where head temperature exceeds 150°F (65°C).

EXTERNAL ADJUSTMENT

An external adjustment at the rear of the 3" and 5" case permits adjustment at a specific point or pointer repositioning during calibration check.

VIBRATION AND SHOCK

If present, use of either a heavy duty bimetal or a remote mounted gas actuated thermometer is recommended.

HIGH PRESSURE OR CORROSIVE APPLICATIONS

In these applications, use of a separable thermowell is recommended. In addition to protecting the thermometer, thermowells facilitate removal of the thermometer without having to shut down the system.

STANDARD FEATURES

- All Stainless Steel Construction
- External Recalibration Adjustment
- White dial with black markings
- Accuracy ±1% of Span
- Gasketed Glass Face
- Case is sealed to exclude dirt, dust and moisture
- 3" and 5" dial sizes
- Angularly adjustable frame permits positioning of dial to accommodate viewing requirements

3" AND 5" DIAL SIZE CATALOG NUMBERS

STEM LENGTH	FIXED THREAD		UNION CONNECTED	
	3"	5"	3"	5"
2½"	CF02	AF02	CU02	AU02
4"	CF04	AF04	CU04	AU04
6"	CF06	AF06	CU06	AU06
9"	CF09	AF09	CU09	AU09
12"	CF12	AF12	CU12	AU12
15"	CF15	AF15	CU15	AU15
18"	CF18	AF18	CU18	AU18
24"	CF24	AF24	CU24	AU24

NOTE: Union connected types must be used with thermowells, longer length available on special order.

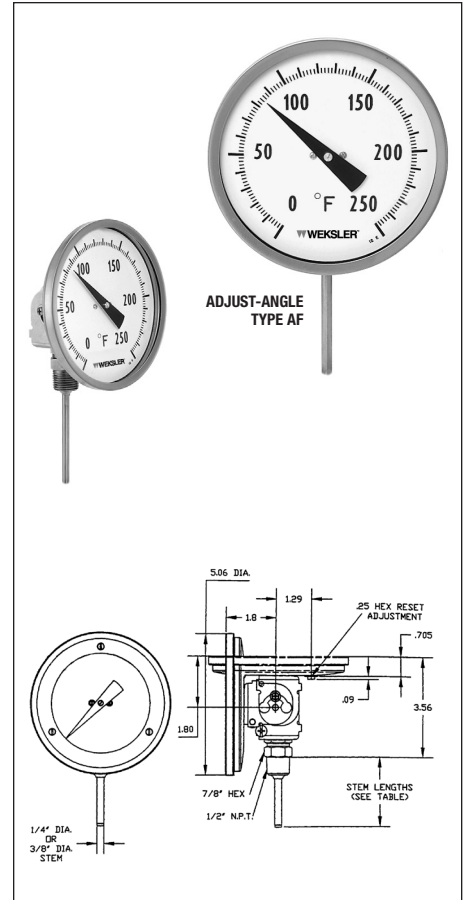

STANDARD RANGES

CODE	Fahrenheit
FC	-80 to 120°F
FE	-40 to 120°F
FG	0 to 150°F
FJ	0 to 200°F
FL	0 to 250°F
FM	30 to 240°F
FN	30 to 130°F †
FR	50 to 300°F
FS	50 to 400°F
FT	50 to 550°F
FX	150 to 750°F †
FY	200 to 1000°F* †

CODE	Celsius
CD	-50 to 50°C
CJ	0 to 100°C
CM	-10 to 110°C
CN	0 to 50°C †
CR	0 to 150°C
CS	0 to 200°C
CU	0 to 300°C
CX	50 to 450°C †
CY	100 to 550°C* †

CODE	DUAL SCALE	
	Fahrenheit (on outside)	Celsius (on inside)
DE	-40/120°F	and -40/50°C
DF	40/160°F	and -40/70°C
DN	30/130°F	and 0/55°C †
DJ	0/200°F	and -20/94°C
DL	0/250°F	and -20/120°C
DR	50/300°F	and 10/150°C
DS	50/400°F	and 10/200°C
DT	50/550°F	and 10/290°C
DX	100/800°F*	and 40/430°C †
DY	200/1,000°F	and 100/550°C* †

*Not recommended for continuous service above 800°F (425°C).
For such temperatures see pg. 63.
†Minimum stem length for these ranges 4".

OPTIONAL FEATURES	
CODE	Description
EL	Liquid Filling
PD	Plastic Window
SG	Shatter Proof Glass
NN	Paper Tag
NH	Stainless Steel Tag
DM	Dial Markings
C4	Calibration Certificate

**SEPARABLE THERMOWELLS AVAILABLE
SEE PAGE 51**

HOW TO ORDER

A F O 6 4 4 F M X

1. Basic 4-digit Catalog No. From Table Above _____
2. Stem Diameter: "4" = .250" O.D. (Standard); "5" = .375" O.D. (Extra Cost) _____
3. Thread Size: "4" = 1/2 NPT Male (AF Series); "U" = 1/2 NPT Male Swivel Nut (AU Series) _____
4. 2 Digit Range Code from Range Tables Above _____
5. Option(s): "X" = None Required; "9" = Option(s) Required (Extra Cost) _____

If option(s) are required specify: Plastic Face, Shatterproof Glass Face, Paper Tag, Stainless Steel Tag

STANDARD FEATURES

- All Stainless Steel Construction
- External Recalibration Adjustment
- White dial with black markings
- Accuracy ±1% of Span
- Gasketed Glass Face
- Case is sealed to exclude dirt, dust and moisture
- 3" dial size

CATALOG NUMBERS*		
STEM LENGTH	90° BACK ANGLE FORM	LOWER STRAIGHT FORM
2½"	3A02	3S02
4"	3A04	3S04
6"	3A06	3S06
9"	3A09	3S09
12"	3A12	3S12
15"	3A15	3S15
18"	3A18	3S18
24"	3A24	3S24

Longer stem lengths available on special order.

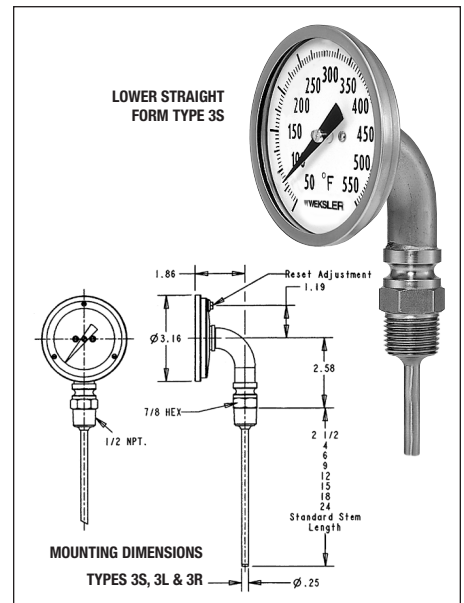
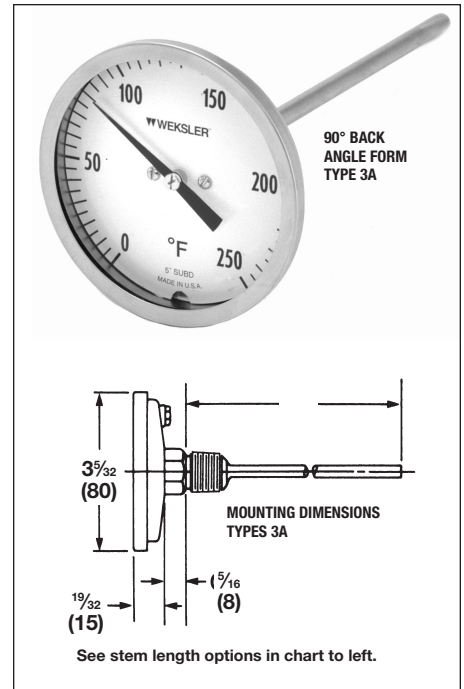

STANDARD RANGES

CODE	Fahrenheit
FC	-80 to 120°F
FE	-40 to 120°F
FG	0 to 150°F
FJ	0 to 200°F
FL	0 to 250°F
FM	30 to 240°F
FN	30 to 130°F †
FR	50 to 300°F
FS	50 to 400°F
FT	50 to 550°F
FX	150 to 750°F †
FY	200 to 1000°F †

CODE	Celsius
CD	-50 to 50°C
CJ	0 to 100°C
CM	-10 to 110°C
CN	0 to 50°C †
CR	0 to 150°C
CS	0 to 200°C
CU	0 to 300°C
CX	50 to 450°C †
CY	100 to 550°C †

CODE	DUAL SCALE	
	Fahrenheit (on outside)	Celsius (on inside)
DE	-40/120°F	and -40/50°C
DF	40/160°F	and -40/70°C
DN	30/130°F	and 0/55°C †
DJ	0/200°F	and -20/94°C
DL	0/250°F	and -20/120°C
DR	50/300°F	and 10/150°C
DS	50/400°F	and 10/200°C
DT	50/550°F	and 10/290°C
DX	100/800°F*	and 40/430°C †
DY	200/1,000°F	and 100/550°C †

*Not recommended for continuous service above 800°F (425°C).
 †For such temperatures see pg. 63.
 †Minimum stem length for these ranges 4".

OPTIONAL FEATURES	
CODE	Description
EL	Liquid Filling NA on 3S
PD	Plastic Window
SG	Shatter Proof Glass
NN	Paper Tag
NH	Stainless Steel Tag
DM	Dial Markings
C4	Calibration Certificate

**SEPARABLE THERMOWELLS AVAILABLE
SEE PAGE 51**

HOW TO ORDER

3 S 0 4 4 4 D R X

1. Basic 4-digit Catalog No. From Table Above _____
2. Stem Diameter: "4" = .250" O.D. (Standard); "5" = .375" O.D. (Extra Cost) _____
3. Thread Size: "4" = 1/2 NPT Male; 2 = 1/4 NPT Male Back Angle Rear Only (Extra Cost) _____
4. 2 Digit Range Code from Range Tables Above _____
5. Option(s): "X" = Non Required Option(s) Required (Extra Cost) Select code from above table _____

STANDARD FEATURES

- All Stainless Steel Construction
- External Recalibration Adjustment
- White dial with black markings
- Accuracy ±1% of Span
- Gasketed Glass Face
- Case is sealed to exclude dirt, dust and moisture
- 5" dial size

CATALOG NUMBERS*		
STEM LENGTH	90° BACK ANGLE FORM	LOWER STRAIGHT FORM
2½"	5A02	5S02
4"	5A04	5S04
6"	5A06	5S06
9"	5A09	5S09
12"	5A12	5S12
15"	5A15	5S15
18"	5A18	5S18
24"	5A24	5S24

Longer stem lengths available on special order

STANDARD RANGES

CODE	Fahrenheit
FC	-80 to 120°F
FE	-40 to 120°F
FG	0 to 150°F
FJ	0 to 200°F
FL	0 to 250°F
FM	30 to 240°F
FN	30 to 130°F †
FR	50 to 300°F
FS	50 to 400°F
FT	50 to 550°F
FX	150 to 750°F †
FY	200 to 1000°F †

CODE	Celsius
CD	-50 to 50°C
CJ	0 to 100°C
CM	-10 to 110°C
CN	0 to 50°C
CR	0 to 150°C
CS	0 to 200°C
CU	0 to 300°C
CX	50 to 450°C †
CY	100 to 550°C †

**SEPARABLE THERMOWELLS AVAILABLE
SEE PAGE 51**

CODE	DUAL SCALE	
	Fahrenheit (on outside)	Celsius (on inside)
DE	-40/120°F	and -40/50°C
DF	40/160°F	and -40/70°C
DN	30/130°F	and 0/55°C †
DJ	-0/200°F	and -20/94°C
DL	0/250°F	and -20/120°C
DR	50/300°F	and 10/150°C
DS	50/400°F	and 10/200°C
DT	50/550°F	and 10/290°C
DX	100/800°F*	and 40/430°C †
DY	200/1,000°F	and 100/550°C †

*Not recommended for continuous service above 800°F (425°C).
For such temperatures see pg. 63.
†Minimum stem length for these ranges 4".

OPTIONAL FEATURES	
CODE	Description
EL	Liquid Filling NA on 5S
PD	Plastic Window
SG	Shatter Proof Glass
NN	Paper Tag
NH	Stainless Steel Tag
DM	Dial Markings
C4	Calibration Certificate

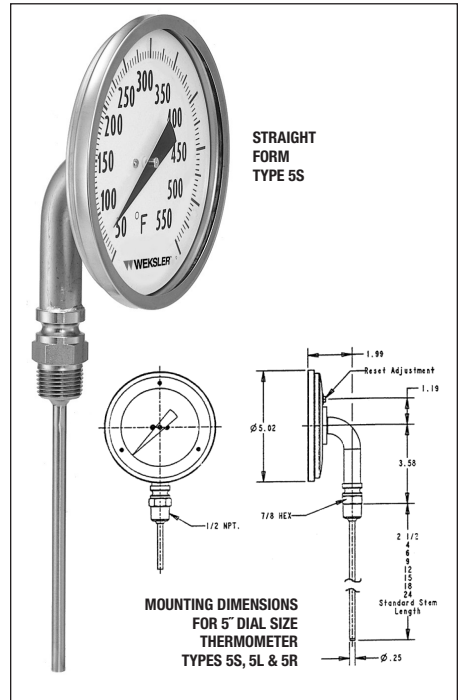
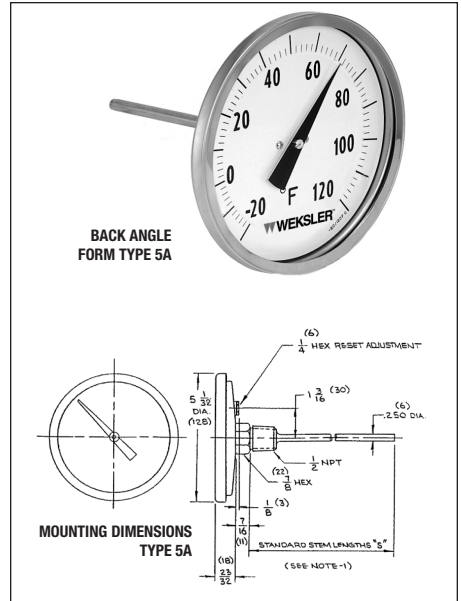

HOW TO ORDER

5 A 0 6 4 4 F J X

- Basic 4-digit Catalog No. From Table Above _____
- Stem Diameter: "4" = .250" O.D. (Standard); "5" = .375" O.D. (Extra Cost) _____
- Thread Size: "4" = 1/2 NPT Male; 2 = 1/4 NPT Male, Back Angle Rear Only (Extra Cost) _____
- 2 Digit Range Code from Range Tables Above _____
- Option(s): "X" = Non Required Option(s) Required (Extra Cost) Select code from above table _____

STANDARD FEATURES

- Shock and Vibration Resistant
- Stainless Steel Construction
- Plastic Crystal
- Dished Anti-Parallax Dial for Easy Reading
- External Recalibration Adjustment at Rear of Case
- Accuracy 1% of Span(when tested without well)
- Interchangeable with 5" Scale Size "Submarine" Thermometers Having Same Stem Length
- 3/4"-28 UN2A Union Connection Assembly Must be used with Well (or Bushing)

STEM LENGTH	CATALOG NUMBERS	
	90° BACK ANGLE FORM	STRAIGHT FORM
2"	H3A2	H3S2
4"	H3A4	H3S4
6"	H3A6	H3S6

NOTE: A minimum of 2" insertion (immersion) is required for accurate readings and proper response.

CODE	Fahrenheit
D	-40 to 120°F in 2° divs.*
H	0 to 200°F in 2° divs.
L	20 to 240°F in 2° divs.
P	50 to 300°F in 2° divs.
Q	50 to 400°F in 5° divs.
R	50 to 500°F in 5° divs.
S	50 to 750°F in 10° divs.

CODE	Celsius
1	-50 to 50°C in 1° divs.*
2	-10 to 110°C in 1° divs.
5	0 to 150°C in 2° divs.
6	0 to 200°C in 2° divs.
8	0 to 300°C in 5° divs.

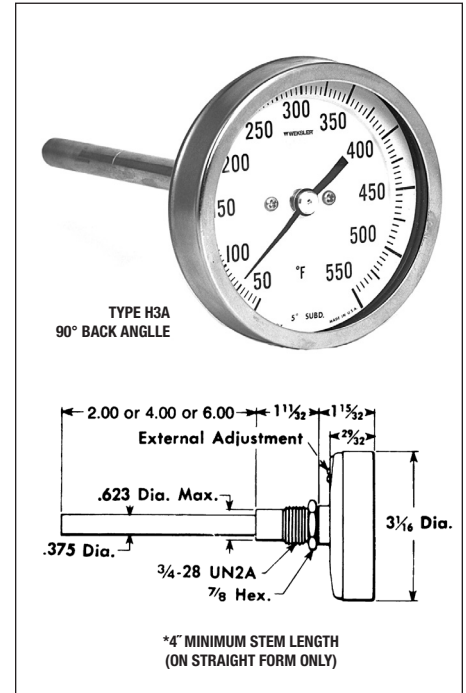

HOW TO ORDER

H 3 S 4 H

1. Basic 4-digit Catalog No. _____
2. Range Code _____

**THERMOWELLS FOR HEAVY DUTY BIMETAL THERMOMETERS
.385" BORE – 3/4-28" FEMALE THREAD (INTERNAL)**

THREADED TYPE – 3/4-14 NPT MALE

THERMOMETER STEM LENGTH	WELL LENGTH (OVERALL)	CATALOG NO.
		304 SS
2"	3 1/4"	W3G1
4"	5 1/4"	W5G1
6"	7 1/4"	W7G1

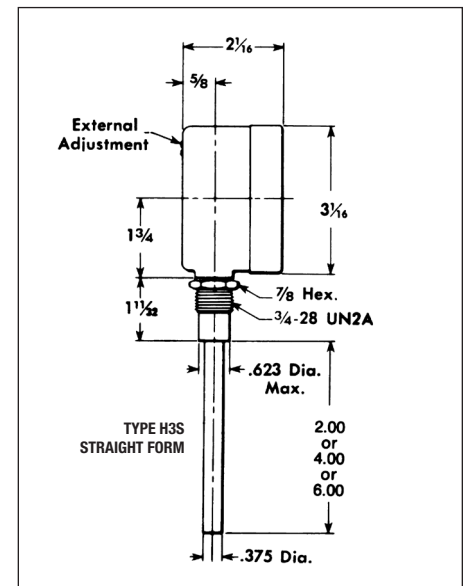
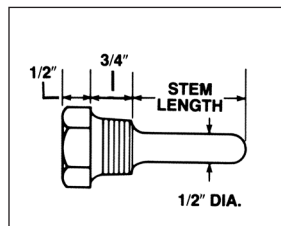

To Order: Specify 4 digit catalog no. from above tables

STANDARD FEATURES

- 1" dial
- 5" stem length
- .142" stem diameter
- Complete with pocket case and clip
- Standard with plastic crystal and recalibration feature

CATALOG NUMBER	STANDARD RANGES
1R05A	-40 to 160°F in 2° divs.
1R05B	25 to 125°F in 1° divs.
1R05C	0 to 220°F in 2° divs.
1R05D	50 to 550°F in 5° divs.
1R05E	-50 to 100°C in 2° divs.
1R05F	-10 to 110°C in 2° divs.
1R05G	0 to 150°C in 2° divs.
1R05H	0 to 250°C in 5° divs.

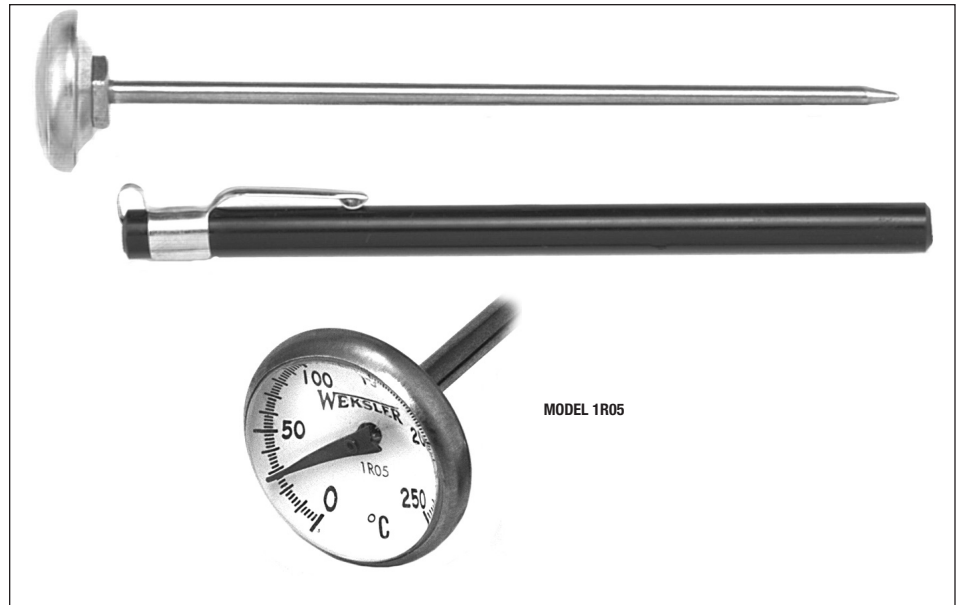

MODEL 1R05

STANDARD FEATURES

- 2" dial
- All Stainless Steel Construction
- Accuracy $\pm 1\%$ of Span
- Dual Scale (Both °F and °C) Ranges

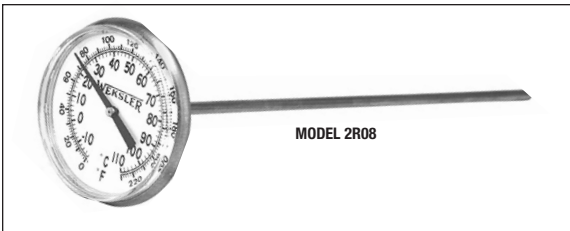

MODEL 2R08



MODEL 2T02

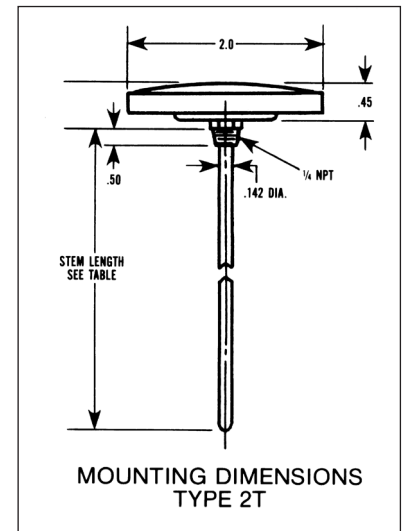

MOUNTING CLIP FOR 1" and 2" PN TPC

CATALOG NUMBER	DUAL SCALE (BOTH °F AND °C) FAHRENHEIT ON OUTER – CELSIUS ON INNER SCALE		TYPE
2R08A	-40 to 160°F in 2° divs.	and -40 to 70°C in 2° divs.	8" Plain Stem With Recalibration Feature
2R08B	25 to 125°F in 1° divs.	and -5 to 50°C in 1° divs.	
2R08J	0 to 180°F in 2° divs.	and -18 to 83°C in 1° divs.	
2R08C	0 to 220°F in 1° divs.	and -10 to 110°C in 2° divs.	
2R08K	50 to 400°F in 5° divs.	and 10 to 106°C in 2° divs.	
2R08D	50 to 550°F in 5° divs.	and 10 to 290°C in 5° divs.	
2T02A	-40 to 160°F in 2° divs.	and -40 to 70°C in 2° divs.	2½" Stem ¼ NPT Fixed Thread
2T02C	0 to 220°F in 2° divs.	and -10 to 110°C in 2° divs.	
2T04A	-40 to 160°F in 2° divs.	and -40 to 70°C in 2° divs.	4" Stem ¼ NPT Fixed Thread
2T04B	25 to 125°F in 1° divs.	and -5 to 50°C in 1° divs.	
2T04C	0 to 220°F in 2° divs.	and -10 to 110°C in 2° divs.	

HOW TO ORDER

Specify 5 digit catalog number from above tables

**FOR INDUSTRIAL BIMETAL THERMOMETERS
WITH .250" DIAMETER ELEMENTS**

- .385" bore available for use with instruments with .375" diameter elements
- All Weksler standard thermowells are bored from solid bar stock

3/4 NPT – CATALOG NUMBERS

A	U	Q	BRASS	304 SS	316 SS
4	2½	—	S3B4	S3G4	S3J4
6	4½	¾	S3B6	S3G6	S3J6
9	7½	¾	S3B9	S3G9	S3J9
12	10½	¾	S3B2	S3G2	S3J2

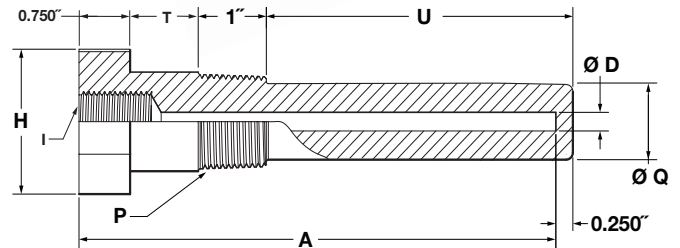
THREADED STRAIGHT THERMOWELL WITHOUT LAGGING EXTENSION

THREADED STRAIGHT - 0.260 & 0.385 BORE

P	H	Q 0.260 Bore	Q 0.385 Bore
½"	1.125"	0.50"	0.625"
¾"	1.125"	0.50"	0.625"
1"	1.375"	0.50"	0.625"

THERMOWELL LEGEND

- I - Instrument connection
- P - Process connection
- T - Lag dimension when required
- B - Root OD
- E - Tip OD
- D - Bore diameter
- U - Insertion depth
- S - Instrument stem length or bore depth

Brass wells are not recommended for installations involving high pressures and/or temperatures over 400°F.
Brass cap and chain available to keep bore clean when not in use.

.260" bore standard. If .385" bore is required:

(1) Add the letter K at the end of the catalog no.;

(2) "Q" diameter is changed to 49/64" along entire length of insertion ("U" dimension).

For pressure – temperature rating use Table 1 on page 89.

NOTE: 2½" STEM THERMOMETERS USE SPECIAL LIMITED SPACE WELLS.

GLASS THERMOMETERS

Adjustable Angle Glass Thermometers	55
Dimensions, Thermowells.....	56

STANDARD FEATURES

- Mercury Free.
- Molded Valox® – V-shaped black case for ranges up to and including 300°F
- Die cast black aluminum V-shaped case for ranges above 300°F.
- Glass front excludes dust and dirt.
- White aluminum scale with bold black graduations and figures.
- Mercury Free blue liquid in glass with magnifying lens for easy readability.
- Accuracy is $\pm 1\%$ of span.
- Easy adjustment permits case and stem to be rotated 360°.
- 3½", 6", 9" & 12" stems available.
- 1¼"-18" NEF swivel nut.

OPTIONS

- Plastic window available for both 7" and 9" scale.
- Aluminum case available for low ranges (300°F and below).

RANGES

FAHRENHEIT	MINOR GRADS	RANGE CODE
-40/110F	2°	F1
0/120F	1°	F2
0/160F	2°	F3
30/180F	2°	F4
30/240F	2°	F5
30/300F	5°	F6
50/400F ⁽¹⁾	5°	F7
50/550F ⁽¹⁾	5°	F8
CELSIUS		
-20/45C	1°	C1
0/50C	1°	C2
0/100C	1°	C3
0/160C ⁽¹⁾	2°	C4
0/200C ⁽¹⁾	2°	C5
0/300C ⁽¹⁾	5°	C6
DUAL SCALE		
-40/110F & -40/43C	2°	D1
0/120F & -15/48C	1°	D2
0/160F & -15/70C	2°	D3
30/180F & 0/82C	2°	D4
30/240F & 0/115C	2°	D5
30/300F & 0/150C	5°	D6
50/400F & 10/200C ⁽¹⁾	5°	D7
50/550F & 10/290C ⁽¹⁾	5°	D8

(1) Must be supplied with optional aluminum case.

STOCK THERMOMETERS

A735AF2	A935AF4	A935AF2-AL
A735AF5	A935AF5	A935AF3-AL
A935AD2	A935AF6	A935AF4-AL
A935AF2	A960AF2	A935AF5-AL
A935AF3	A960AF5	A935AF6-AL
-	-	A960AF2-AL

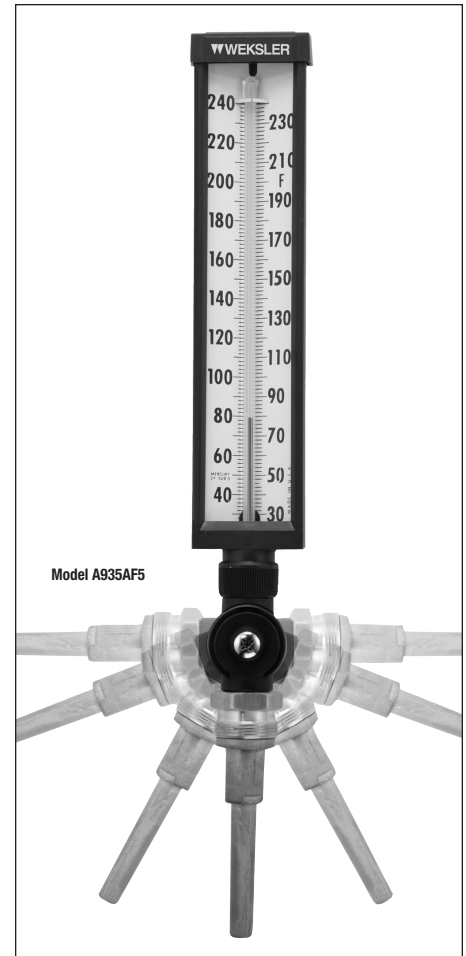

HOW TO ORDER

1. Product Type: **A**
2. Scale Size: 7 = 7" Scale; 9 = 9" Scale **9**
3. Stem Length: 35 = 3½"; 60 = 6"; 90 = 9" **35**
4. Connection Location: A = Adjustable Angle **A**
5. Range (see table) **F5**
6. Options: AL = Aluminum Case*; PD = Plastic Window **— AL**

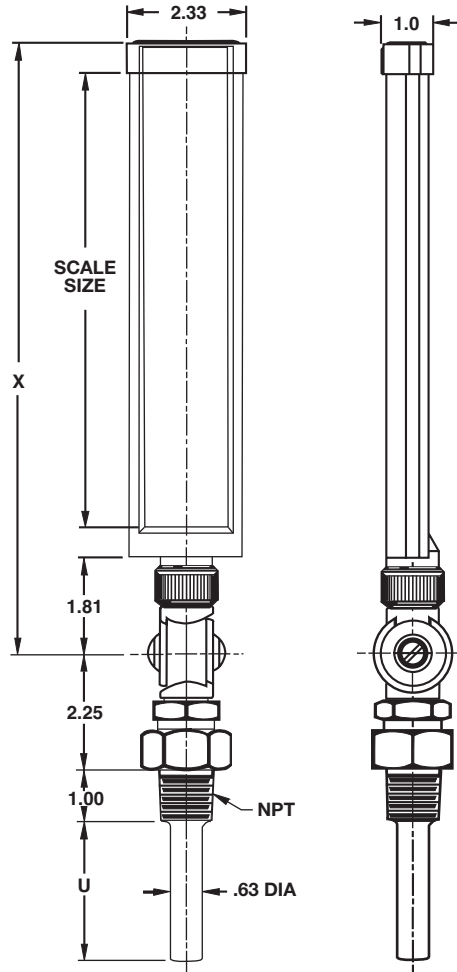
*Aluminum case is required for ranges over 300°F

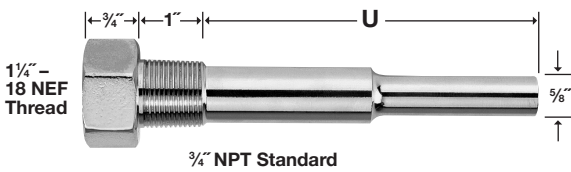

THERMOWELLS FOR ADJUSTABLE ANGLE THERMOMETERS



THERMOMETER STEM LENGTH	"U" DIM.	3/4 NPT BRASS
3 1/2"	2 1/2"	G1E3D2
6"	5"	G1M3D2
9"	8"	G1S3D2
12"	11"	G1T3D2

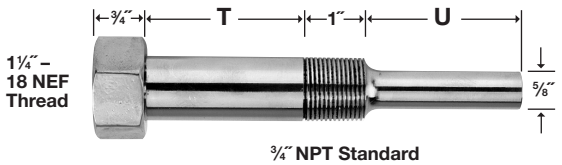

THERMOMETER STEM LENGTH	"T" DIM.	"U" DIM.	3/4 NPT BRASS
3 1/2"	1	1 1/2"	G1E3D2B
6"	2 1/2"	2 1/2"	G1M3D2E
9"	2 1/2"	5 1/2"	G1S3D2E
12"	2 1/2"	8 1/2"	G1T3D2E



Weksler Instruments
250 E. Main Street, Stratford, CT 06614
Tel: 203-378-8281 • Fax: 203-385-0408
www.weksler.com